

Virtual Disk Development Kit Programming Guide

Update 2

VMware vSphere 6.7

Virtual Disk Development Kit 6.7.2



vmware®

You can find the most up-to-date technical documentation on the VMware website at:

<https://docs.vmware.com/>

If you have comments about this documentation, submit your feedback to

docfeedback@vmware.com

VMware, Inc.
3401 Hillview Ave.
Palo Alto, CA 94304
www.vmware.com

Copyright © 2008–2019 VMware, Inc. All rights reserved. [Copyright and trademark information.](#)

Contents

About This Book	9
1 Introduction to the Virtual Disk API	11
About the Virtual Disk API	11
VDDK Components	12
Virtual Disk Library	12
Disk Mount Library	12
Virtual Disk Utilities	12
Backup and Restore on vSphere	12
Backup Design for vCloud Director	13
Use Cases for the Virtual Disk Library	13
Developing for VMware Platform Products	13
Managed Disk and Hosted Disk	14
Advanced Transports	15
VDDK and VADP Compared	15
Platform Product Compatibility	15
Redistributing VDDK Components	15
2 Installing the Development Kit	16
Prerequisites	16
Development Systems	16
Programming Environments	16
VMware Platform Products	17
Storage Device Support	17
Installing the VDDK Package	17
Repackaging VDDK Libraries	18
How to Find VADP Components	19
3 Virtual Disk Interfaces	20
VMDK File Location	20
Virtual Disk Types	20
Persistence Disk Modes	21
VMDK File Naming	21
Thin Provisioned Disk	22
Internationalization and Localization	22
Virtual Disk Internal Format	23
Grain Directories and Grain Tables	23

- Data Structures in Virtual Disk API 23
 - Credentials and Privileges for VMDK Access 24
 - Adapter Types 25
- Virtual Disk Transport Methods 25
 - Local File Access 26
 - SAN Transport 26
 - HotAdd Transport 27
 - NBDSSL Transport 28

4 Virtual Disk API Functions 32

- Virtual Disk Library Functions 32
 - Alphabetic Table of Functions 33
- Start Up 34
 - Initialize the Library 34
 - Connect to a Workstation or Server 35
 - VMX Specification 35
- Disk Operations 36
 - Create a New Hosted Disk 36
 - Open a Local or Remote Disk 36
 - Read Sectors From a Disk 37
 - Write Sectors To a Disk 37
 - Close a Local or Remote Disk 38
 - Get Information About a Disk 38
 - Free Memory from Get Information 38
- Metadata Handling 38
 - Read Metadata Key from Disk 38
 - Get Metadata Table from Disk 38
 - Write Metadata Table to Disk 39
 - Check and Repair Sparse Disk Metadata 39
- Disk Chaining and Redo Logs 39
 - Create Child from Parent Disk 40
 - Attach Child to Parent Disk 40
 - Opening in a Chain 42
 - Redo Logs and Linked Clone Backup 42
- Cloning a Virtual Disk 42
 - Compute Space Needed for Clone 43
 - Clone a Disk by Copying Data 43
- Error Handling 43
 - Return Error Description Text 43
 - Free Error Description Text 43
- Administrative Disk Operations 44
 - Rename an Existing Disk 44

Grow an Existing Local Disk	44
Defragment an Existing Disk	44
Shrink an Existing Local Disk	44
Unlink Extents to Remove Disk	45
Shut Down	45
Disconnect from Server	45
Clean Up and Exit	45
Advanced Transport APIs	45
Initialize Virtual Disk API	45
Phone Home Support	48
Location of Log Files	48
List Available Transport Methods	49
Connect to VMware vSphere	49
Get Selected Transport Method	50
Prepare For Access and End Access	51
SAN Mode on Linux Uses Direct Mode	52
Clean Up After Disconnect	52
Ordering of Function Calls in Sequence	52
Updating Applications for Advanced Transport	52
Algorithm for vSphere Backup	53
Backup and Recovery Example	54
Multithreading Considerations	55
Multiple Threads and VixDiskLib	55
Capabilities of Library Calls	56
Support for Managed Disk	56
Support for Hosted Disk	56
5 Virtual Disk API Sample Code	57
Compiling the Sample Program	57
Visual C++ on Windows	57
C++ on Linux Systems	58
Library Files Required	58
Usage Message	59
Walk-Through of Sample Program	60
Include Files	60
Definitions and Structures	60
Dynamic Loading	61
Wrapper Classes	61
Command Functions	61
SSL Certificate Thumbprint	65

6 Practical Programming Tasks 66

- Scan VMDK for Virus Signatures 66
- Creating Virtual Disks 67
 - Create Local Disk 67
 - Create Remote Disk 68
 - Special Consideration for ESXi Hosts 69
- VMDK File Versions 69
- Working with Virtual Disk Data 69
 - Reading and Writing Local Disk 70
 - Reading and Writing Remote Disk 70
 - Deleting a Disk (Unlink) 70
 - Renaming a Disk 71
- Managing Child Disks 71
 - Create Redo Logs 71
 - Virtual Disk in Snapshots 72
 - Windows 2000 Read-Only File System 72
- RDM Disks and Virtual BIOS 72
 - Restore RDM Disks 73
 - Restore the Virtual BIOS or UEFI 73
- Interfacing With VMware vSphere 74
 - The VIX API 74
 - Virus Scan all Hosted Disk 74
 - The vSphere Web Services API 75
 - Virus Scan All Managed Disk 75
 - Read and Write VMDK Using vSphere API 75
 - First Class Disk (FCD) Backup 76

7 Backing Up Virtual Disks in vSphere 80

- Design and Implementation Overview 80
 - The Backup Process 80
 - Communicating With the Server 81
 - Information Containers as Managed Objects 82
 - Gathering Status and Configuration Information 83
 - Doing a Backup Operation 85
 - Restore a Virtual Machine 86
 - Doing a Restore Operation 87
 - Access Files on Virtual Disks 88
 - More VADP Details 89
- Low Level Backup Procedures 89
 - Communicate with the Server 89
 - The PropertyCollector 90
 - Creating a Snapshot 96

- Backing Up a Virtual Disk 97
- Deleting a Snapshot 98
- New Query Allocated Blocks Function 98
- Changed Block Tracking on Virtual Disks 100
- Low Level Restore Procedures 104
 - Restoring a Virtual Machine and Disk 104
 - Restore Incremental Backup Data 114
 - Restore with Direct Connection to ESXi Host 115
- Tips and Best Practices 115
 - Best Practices for SAN Transport 116
 - Best Practices for HotAdd Transport 117
 - Best Practices for NBDSSL Transport 117
 - General Backup and Restore 118
 - Backup and Restore of Thin-Provisioned Disk 119
 - About Changed Block Tracking 119
 - HotAdd and SCSI Controller IDs 119
 - Encrypted VM Backup and Restore 120
 - Backup and Restore With vTPM 121
- Windows Backup Implementations 123
 - Disable Automount in Windows Proxy 123
 - Security and Remote Desktop 124
 - Working with Microsoft Shadow Copy 124
 - Enable Virtual Machine Application Consistent Quiescing 126
 - Application-Consistent Backup and Restore 126
 - New VSS Support Added in vSphere 6.5 128
 - The VMware VSS Implementation 128
- Linux Backup Implementation 129

8 Backing Up vApps in vCloud Director 130

- Introduction to Tenant vApps 130
 - Prerequisites 131
 - Other Information 132
- Conceptual Overview 132
 - The Backup Process 133
 - The Restore Process 133
- Use Cases Overview 135
 - Managing Credentials 135
 - Finding a vApp 135
 - Protecting Specified vApps 135
 - Recovering an Older Version of a vApp 136
 - Recovering a Deleted vApp 136
 - Recovering a Single Virtual Machine 136

- Backing Up vCloud Director 136
- vCloud API Operations 136
 - Getting Access to vCloud Director 137
 - Inventory Access 137
 - Retrieving Catalog information 141
 - Retrieving vApp Configuration 143
 - Preventing Updates to a vApp During Backup or Restore 145
 - Associating vCloud Resources with vSphere Entities 145
 - Restoring vApps 148
- Conclusion 149

9 Virtual Disk Mount API 151

- The VixMntapi Library 151
 - Types and Structures 151
 - Function Calls 152
- Programming with VixMntapi 158
 - File System Support 158
 - Diagnostic Logging for VixMntapi 158
 - Read-Only Mount on Linux 159
- Sample VixMntapi Code 159
- Restrictions on Virtual Disk Mount 160

10 Errors Codes and Open Source 161

- Recent Changes 161
- Finding Error Code Documentation 161
 - Association With VIX API Errors 161
 - Interpreting Errors Codes 162
- Troubleshooting Dynamic Libraries 162
- Open Source Components 163

About This Book

The VMware[®] *Virtual Disk Development Kit Programming Guide* introduces the Virtual Disk Development Kit (VDDK) and the vSphere Storage APIs – Data Protection (VADP). For VDDK it describes how to develop software using a virtual disk library that provides a set of system-call style interfaces for managing virtual disks on ESXi hosts. For VADP it describes how to write backup and restore software that can be managed by vCenter Server[®] for vSphere.

To view this version or previous versions of this book and other public VMware API and SDK documentation, go to http://www.vmware.com/support/pubs/sdk_pubs.html.

Revision History

Table 1 summarizes the significant changes in each version of this guide.

Table 1. Revision History

Revision	Description
2019-04-11	For vSphere 6.7 Update 2, minor corrections, Storage Spaces stop application quiescing.
2018-10-16	For vSphere 6.7 Update 1, enhancements to VixMntapi library on Linux, more OS support.
2018-04-17	For vSphere 6.7, async NBD, query allocated blocks, First Class Disk, vTPM, phone home.
2017-03-09	Added section to best practices about backing up and restoring encrypted virtual disks.
2017-01-11	Corrections regarding 2TB virtual disk limits, more about ESXi connections.
2016-11-15	Final version for VDDK 6.5. New support for encryption, NBDSSL compression, and VSS extensions.
2016-03-25	Removed statement that disks not associated with a virtual machine can be mounted.
2016-02-02	Fallback to NBDSSL, SCSI order for disk mount, no linked clone SAN restore, EUC non-support.
2015-07-13	Clarified connection port and RAID support, more whitelist details, added Linux freeze and thaw.
2015-05-05	Documented whitelist and blacklist for device path selection, corrected install procedures.
2014-12-26	Final version for VDDK 6.0. Virtual volumes support. SSL certificate checking now mandatory.
2014-04-08	VDDK 5.5.1 supports GPT. Snapshot quiesce and memory are incompatible. Describe VMDK version 3.
2013-11-08	Fixed several errors involving roles and licensing, physical or virtual proxy, and log level.
2013-10-14	Corrections regarding 32-bit Windows and PackageCode. Removed Reparent and Combine APIs.
2013-09-22	Final version for the vSphere 5.5 release, with new chapter on vApp backup for vCloud Director.
2012-12-21	Bug fix version of the vSphere 5.1 manual: numeric change ID policy, mount restrictions.

Table 1. Revision History (Continued)

Revision	Description
2012-10-05	Final version of this manual for the vSphere 5.1 release.
2011-11-18	Bug fix version for 4Q 2011 refresh of the VMware vSphere Documentation Center.
2011-08-22	Final version for the VDDK 5.0 release, subsuming <i>Designing Backup Solutions</i> technical note.
2010-10-12	Bug fix revision for the VDDK 1.2.1 release
2010-08-05	Version for vSphere 4.1 and the VDDK 1.2 public release.
2009-05-29	Final version for the VDDK 1.1 public release.
2008-04-11	Updated version for release 1.0 of the Virtual Disk Development Kit.
2008-01-31	Initial version of the Virtual Disk Development Kit for partner release.

Intended Audience

This guide is intended for developers who are creating applications that manage virtual storage, especially backup and restore applications. It assumes knowledge of C and C++ programming. For VADP development, this guide assumes knowledge of Java.

Supported Platform Products

You can develop VDDK programs using either Linux or Windows, and test them using VMware Workstation or ESXi and vSphere. To develop and test VADP programs, you need a vCenter Server and ESXi hosts, preferably with shared cluster storage.

Document Feedback

VMware welcomes your suggestions for improving our developer documentation. Send your feedback to docfeedback@vmware.com.

VMware Technical Publications

VMware Technical Publications provides a glossary of terms that might be unfamiliar to you. For definitions of terms as they are used in VMware technical documentation go to <http://www.vmware.com/support/pubs>.

To access the current versions of VMware manuals, go to <http://pubs.vmware.com/vsphere-50/index.jsp>.

Introduction to the Virtual Disk API



The virtual disk development kit (VDDK) is an SDK to help developers create applications that access storage on virtual machines. The VDDK package is based on the virtual disk API, introduced in this chapter.

The VMware Storage APIs – Data Protection (VADP) use the virtual disk API and a subset of vSphere APIs to take snapshots of virtual machines running on ESXi, enabling full or incremental backup and restore. VADP replaces VMware Consolidated Backup (VCB).

This chapter includes the following topics:

- [About the Virtual Disk API](#)
- [VDDK Components](#)
- [Use Cases for the Virtual Disk Library](#)
- [Developing for VMware Platform Products](#)

About the Virtual Disk API

The virtual disk API, or VixDiskLib, is a set of function calls to manipulate virtual disk files in VMDK format (virtual machine disk). Function call semantics are patterned after C system calls for file I/O. Using the virtual disk API, you can write programs to manage VMDK files directly from your software applications.

These library functions can manipulate virtual disks on VMware Workstation or similar products (hosted disk) or virtual disks residing on file system volumes of an ESXi host managed by vCenter Server (managed disk). Hosted is a term meaning that the virtualization platform and disk are hosted by a guest operating system such as Windows or Linux.

The VDDK package installs on either Windows or Linux, so you can write VDDK and VADP applications using either system. Applications can manipulate the virtual disks of any operating system that runs on a supported VMware platform product. You may repackage VDDK binaries into your software application after signing a redistribution agreement. See the *VDDK Release Notes* for a list of supported platform products and development systems.

The VDDK and VADP enable you to develop applications that work effectively across multiple virtual disks from a central location.

VDDK Components

The virtual disk development kit includes the following components:

- The virtual disk library, a set of C function calls to manipulate VMDK files
- The disk mount library, a set of C function calls to remote mount VMDK file systems
- C++ code samples that can be compiled with Visual Studio or the GNU C compiler
- PDF manuals and online HTML reference

Virtual Disk Library

VixDiskLib is a standalone wrapper library to help you develop solutions that integrate into VMware platform products. The virtual disk library has the following capabilities:

- It allows programs to create, convert, expand, defragment, shrink, and rename virtual disk files.
- It can create redo logs (parent-child disk chaining, or deltas) and it can delete VMDK files.
- It permits random read/write access to data anywhere in a VMDK file, and reads metadata.
- It can connect to remote vSphere storage using advanced transports, SAN or HotAdd.

For Windows, the virtual disk kernel-mode driver should be 64-bit. User libraries could be 32-bit because Windows On Windows 64 can run 32-bit programs without alteration. VMware provides only 64-bit libraries.

Disk Mount Library

The virtual disk mount library, vixMntapi, allows programmatic access of virtual disks as if they were mounted disk partitions. For more information see [Chapter 9 Virtual Disk Mount API](#). The vixMntapi library is packaged in the VDDK with vixDiskLib.

Virtual Disk Utilities

The Virtual Disk Development Kit used to include two command-line utilities for managing virtual disk files: disk mount and virtual disk manager. They were last delivered in the VDDK 5.0 release. For more information see the old *Disk Mount and Virtual Disk Manager User's Guide*, still available on the Web.

Backup and Restore on vSphere

The VMware Storage APIs – Data Protection (VADP) is a collection of APIs that are useful for developing or extending backup software so it can protect virtual machines running on ESXi hosts in VMware based datacenters. For more information see [Chapter 7 Backing Up Virtual Disks in vSphere](#).

Backup Design for vCloud Director

With VMware vCloud[®], the self-service capabilities of vCloud Director provide three levels of data protection. Backup providers can offer vApp protection at the system level, the tenant level, or the end-user level. For information about vCloud data protection, see the technical note [Backup Design for vCloud Tenant vApps](#).

Use Cases for the Virtual Disk Library

The library provides access to virtual disks, enabling a range of use cases for application vendors including:

- Back up a particular volume, or all volumes, associated with a virtual machine.
- Connect a backup proxy to vSphere and back up all virtual machines on a storage cluster.
- Read virtual disk and run off-line anti-virus scanning, or package analysis, of virtual machines.
- Write to virtual disk to perform off-line centralized patching of virtual machines.
- Manipulate virtual disks to defragment, expand, convert, rename, or shrink the file system image.
- Perform data recovery or virus cleaning on corrupt or infected off-line virtual machines.

Developing for VMware Platform Products

In a VMware based data center, commercial backup software is likely to access virtual disks remotely, perhaps from a backup proxy. The proxy can be a virtual machine or a physical machine with backup-restore software installed and access to alternate storage such as a tape autochanger or equivalent.

At a given point in time, during the backup window, backup software:

- Snapshots virtual machines in a cluster, one by one, or in parallel. Virtual machines run off the snapshot.
- Copies the quiesced base disk, or (for incremental backup) only changed blocks, to backup media.
- Records the configuration of virtual machines.
- Reverts and deletes snapshots, so virtual machines retain any changes made during the backup window.

In the above procedure, the virtual disk library is used in the second step only. The other steps use a portion of the vSphere API (called VADP) to snapshot and save configuration of virtual machines. The virtual disk in a cluster is “managed” by vSphere.

Managed Disk and Hosted Disk

Analogous to a hard disk drive, virtual disk files represent the storage volumes of a virtual machine. Each is named with .vmdk suffix. On a system running VMware Workstation, file systems of each guest OS are kept in VMDK files hosted on the system’s physical disk. VMDK files can be accessed directly on the host.

With the virtual machine file system (VMFS) on ESXi hosts, VMDK files again represent storage volumes of virtual machines. They are on VMFS, which often resides on shared storage in a cluster. The vCenter Server manages the cluster storage so it can migrate (vMotion) virtual machines from one ESXi host to another without moving VMDK files. VMFS storage is therefore called managed disk.

VMFS disk can reside on a storage area network (SAN) attached to ESXi hosts by Fibre Channel, iSCSI, or SAS connectors. It can also reside on network attached storage (NAS), or on directly attached disk.

Figure 1-1 depicts the arrangement of managed disk, as VMDK files in a SAN based cluster. Figure 1-2 depicts hosted disk on VMware Workstation, as VMDK files on physical disk.

Figure 1-1. Managed Disk on vSphere

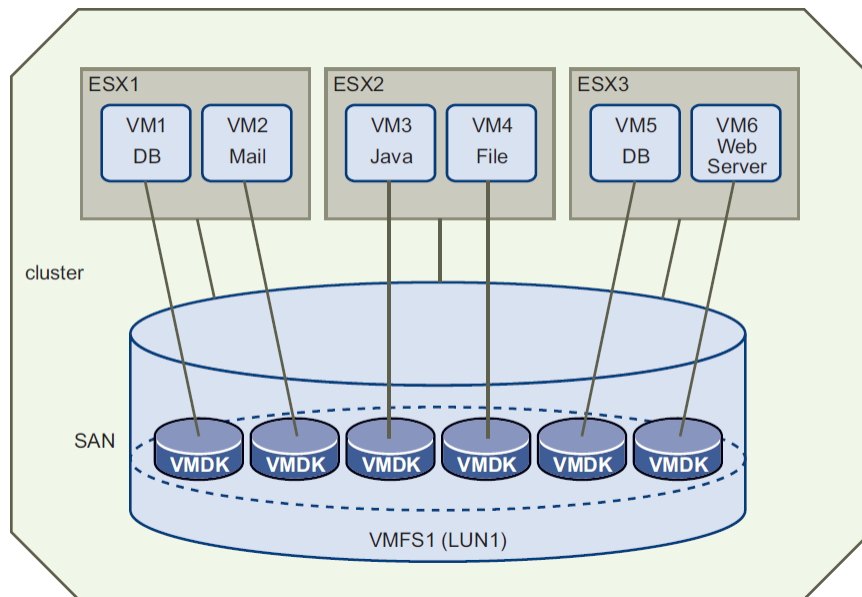
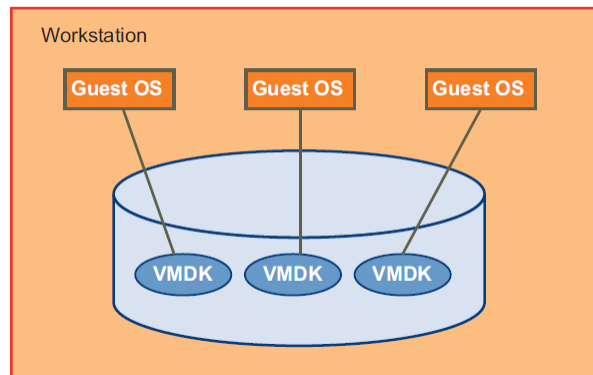

Figure 1-2. Hosted Disk on Workstation



The VDDK supports both managed disk and hosted disk. Some functions are not supported for managed disk, and others are not supported for hosted disk, as noted in documentation. Managed virtual disk files larger than 2TB are supported by vSphere 5.5 and later.

Advanced Transports

With managed disk, VDDK applications can make use of advanced transports to perform many I/O operations directly on the SAN, rather than over the LAN. This improves performance and saves network bandwidth.

VDDK and VADP Compared

The Virtual Disk Development Kit (VDDK) includes a set of C library routines for manipulating virtual disk (VixDiskLib) and for mounting virtual disk partitions (VixMntapi). The VDDK focuses on efficient access and transfer of data on virtual disk storage.

The vSphere Storage APIs for Data Protection (VADP) is a marketing term for a subset of the vSphere API that enables backup and restore applications. The snapshot-based VADP framework allows efficient, off-host, centralized backup of virtual machine storage. After taking a snapshot to quiesce virtual disk, software can then back up storage using VDDK library routines.

The vSphere API is an XML-based Web service that provides the interfaces for vCenter Server management of virtual machines running on ESXi hosts.

Developers need both VDDK and VADP to write data protection software. VADP is presented in [Chapter 7 Backing Up Virtual Disks in vSphere](#).

Platform Product Compatibility

To support a new release of vSphere, in most cases you should update and recompile your software with a corresponding new release of VDDK. This is because VDDK is continually updated to support new features in vSphere. As of 5.0, the version number of VDDK matches the version number of vSphere.

Since its inception in 2008, VDDK has been backward compatible with virtual platform products such as VMware Workstation, ESXi, and vCenter Server. VMware Fusion was never supported.

Redistributing VDDK Components

After you use the VDDK to develop software applications that run on VMware platform products, you might need to repackage library components that are compiled into your software.

To qualify for VDDK redistribution, you must be in the VMware TAP program at Select level or above, and sign a redistribution agreement. Contact your VMware alliance manager to request the VDDK redistribution agreement. VMware would like to know how you use the VDDK, in what products you plan to redistribute it, your company name, and your contact information.

Installing the Development Kit

To develop virtual disk applications, install the VDDK as described in this chapter. For backup applications, VADP development also requires the vSphere Web Services SDK.

This chapter includes the following topics:

- [Prerequisites](#)
- [Installing the VDDK Package](#)

Prerequisites

This section covers what you need to begin VDDK and VADP development.

Development Systems

The VDDK has been tested and is supported on the following systems:

- Windows 64-bit (x86-64) systems
- Linux 64-bit (x86-64) systems

See the *VDDK Release Notes* for specific versions, which change over time. Mac OS X is not supported.

Programming Environments

You can compile the sample program and develop vSphere applications in the following environments:

Visual Studio on Windows

On Windows, programmers can use the C++ compiler in Visual Studio 2005, Visual Studio 2008, and later. Along with Visual Studio, you also need to install the 64-bit debugging tools.

C++ and C on Linux

On Linux, programmers can use the GNU C compiler, version 4 and higher. The sample program compiles with the C++ compiler `g++`, but VDDK also works with the C compiler `gcc`.

Java Development for VADP

When developing backup and restore software to run on vSphere, VMware recommends Eclipse with Java, on both Windows and Linux. The vSphere Web Services SDK now includes both Axis and JAX-WS bindings. You can call C or C++ code with wrapper classes, as in Java Native Interface (JNI).

VMware Platform Products

Software applications developed with the VDDK and VADP target the following platform products:

- vCenter Server managing ESXi hosts
- ESXi hosts directly connected

See the *VDDK Release Notes* for specific versions, which change over time.

Hosted products including VMware Workstation are neither tested nor supported.

Storage Device Support

VMware Consolidated Backup (VCB) had knowledge base article <http://kb.vmware.com/kb/1007479> showing the support matrix for storage devices and multipathing. VMware does not provide a similar support matrix for VDDK and VADP. Customers must get this information from you, their backup software vendor.

Installing the VDDK Package

The VDDK is packaged as a compressed archive for Windows 64-bit and for Linux 64-bit. The VDDK packages include the following components:

- Header files `vixDiskLib.h` and `vm_basic_types.h` in the `include` directory.
- Function library `vixDiskLib.lib` (Windows) or `libvixDiskLib.so` (Linux) in the `lib` directory.
- HTML reference documentation in the `doc` directory and sample program in `doc/samples`.

Note In the VDDK 5.5 release, VMware discontinued the Windows installer and 32-bit executables for Windows and Linux. The VDDK is available for 64-bit systems only.

To install the package on Windows:

- 1 On the Download page, choose the `.zip` file for Windows and download it to your development system.
- 2 Place the `.zip` file in a folder under Program Files – you can choose the name – and unpack it:

```
cd C:\Program Files\VMware\VDDK670
unzip VMware-vix-disklib-*.zip
```

- 3 Go to the `bin` subfolder, locate the `vstor2install.bat` script, and double-click to run it. The batch script should be run in place so that the current directory for execution is the `bin` subfolder. By running it, you implicitly accept the VMware license terms.

Note If `vstor2` is already installed on a backup proxy, you should first uninstall it with `vstor2uninstall.bat` (from its corresponding VDDK version) then run the new install script.

- 4 Edit the Windows registry with `regedit` and check for the following key. If this key exists from a previous VDDK install, right-click to delete it. Add a registry entry with the following key:

```
HKEY_LOCAL_MACHINE\SOFTWARE\Wow6432Node\VMware, Inc.\VMware Virtual Disk
Development Kit
```

For convenience you might want to edit the Windows Path environment to include the VDDK installation folder, `C:\Program Files\VMware\VDDK550\bin` in the example above.

To Install the package on Linux:

- 1 On the Download page, choose the binary `tar.gz` for 64-bit Linux.
- 2 Unpack the archive with `tar` to create the `vmware-vix-disklib-distrib` subdirectory.

```
$ tar xvzf VMware-vix-disklib-*.tar.gz
```

- 3 Change to the newly created directory to see its subdirectories:

```
$ cd vmware-vix-disklib-distrib; ls
bin64 doc FILES include lib32 lib64
```

The `bin64` subdirectory contains a reporting program and virtual disk manager. License terms are in the `doc/EULA` file. The sample program is under `doc/samples`. Header files in the `include` subdirectory are for compiling your VDDK applications. Normally the `lib64` components are installed under `/usr/lib`, `/usr/lib/vmware-vix-disklib/lib64` for instance.

- 4 Install components as needed. You might want to edit your `LD_LIBRARY_PATH` environment to include the library installation path. Alternatively, you can add the library location to the list in `/etc/ld.so.conf` and run `ldconfig` as the superuser.

Repackaging VDDK Libraries

After you develop an application based on VDDK, you might need the VDDK binaries to run your application.

As described in [Redistributing VDDK Components](#), partners can sign a license agreement to redistribute VDDK binaries that support VADP applications.

To enable VDDK binaries on Windows virtual machines without VDDK installed

Procedure

- 1 Install the Microsoft Visual C++ (MSVC) redistributable, possibly as a merge module. The latest MSVC runtime works as side-by-side component, so manually copying it might not work on Vista. See details on the Microsoft Web site for the redistributable package, x86 processors or x64 processors. Side-by-side is also explained on the Microsoft Web site.
- 2 Install VMware executables and DLLs from the `\bin` and `\lib` folders of the installed VDDK, and the `vstor2-mntapi10.sys` driver into the `Windows\system\drivers` folder or equivalent.
- 3 Create and install your application, compiled in a manner similar to the `vixDiskLibSample.exe` code, discussed in [Chapter 5 Virtual Disk API Sample Code](#).

How to Find VADP Components

ESXi hosts and vCenter Server similarly implement managed objects that support inventory traversal and task requests. Before you write VADP software in Java, you need to download the vSphere Web Services SDK. You can find documentation and ZIP file for download on the VMware Web site.

Virtual Disk Interfaces

VMware offers many options for virtual disk layout, encapsulated in library data structures described here.

This chapter includes the following topics:

- [VMDK File Location](#)
- [Virtual Disk Types](#)
- [Data Structures in Virtual Disk API](#)
- [Virtual Disk Transport Methods](#)

VMDK File Location

On ESXi hosts, virtual machine disk (VMDK) files are usually located under one of the `/vmfs/volumes`, perhaps on shared storage. Storage volumes are visible from the vSphere Client, in the inventory for hosts and clusters. Typical names are `datastore1` and `datastore2`. To see a VMDK file, click **Summary > Resources > Datastore**, right-click **Browse Datastore**, and select a virtual machine.

On Workstation, VMDK files are stored in the same directory with virtual machine configuration (VMX) files, for example `/path/to/disk` on Linux or `C:\My Documents\My Virtual Machines` on Windows.

VMDK files store data representing a virtual machine's hard disk drive. Almost the entire portion of a VMDK file is the virtual machine's data, with a small portion allotted to overhead.

Virtual Disk Types

The following disk types are defined in the virtual disk library:

- `VIXDISKLIB_DISK_MONOLITHIC_SPARSE` – Growable virtual disk contained in a single virtual disk file. This is the default type for hosted disk, and the only setting in the [Chapter 5 Virtual Disk API Sample Code](#) sample program.
- `VIXDISKLIB_DISK_MONOLITHIC_FLAT` – Preallocated virtual disk contained in a single virtual disk file. This takes time to create and occupies a lot of space, but might perform better than sparse.
- `VIXDISKLIB_DISK_SPLIT_SPARSE` – Growable virtual disk split into 2GB extents (s sequence). These files can to 2GB, then continue growing in a new extent. This type works on older file systems.

- VIXDISKLIB_DISK_SPLIT_FLAT – Preallocated virtual disk split into 2GB extents (f sequence). These files start at 2GB, so they take a while to create, but available space can grow in 2GB increments.
- VIXDISKLIB_DISK_VMFS_FLAT – Preallocated virtual disk compatible with ESX 3 and later. Also known as thick disk. This managed disk type is discussed in [Managed Disk and Hosted Disk](#).
- VIXDISKLIB_DISK_VMFS_SPARSE – Employs a copy-on-write (COW) mechanism to save storage space.
- VIXDISKLIB_DISK_VMFS_THIN – Growable virtual disk that consumes only as much space as needed, compatible with ESX 3 or later, supported by VDDK 1.1 or later, and highly recommended.
- VIXDISKLIB_DISK_STREAM_OPTIMIZED – Monolithic sparse format compressed for streaming. Stream optimized format does not support random reads or writes.

Persistence Disk Modes

In persistent disk mode, changes are immediately and permanently written to the virtual disk, so that they survive even through to the next power on.

In nonpersistent mode, changes to the virtual disk are discarded when the virtual machine powers off. The VMDK files revert to their original state.

The virtual disk library does not encapsulate this distinction, which is a virtual machine setting.

VMDK File Naming

[Table 3-1](#) explains the different types of virtual disk. The first column corresponds to [Virtual Disk Types](#) but without the VIXDISKLIB_DISK prefix. The third column gives the possible names of VMDK files as implemented on Workstation and ESXi hosts.

Note When you open a VMDK file with the virtual disk library, always open the one that points to the others, not the split or flat sectors. The file to open is most likely the one with the shortest name.

For information about other virtual machine files, see section “Files that Make Up a Virtual Machine” in the *VMware Workstation User’s Manual*. On ESXi hosts, VMDK files are type VMFS_FLAT or VMFS_THIN.

Table 3-1. VMDK Virtual Disk Files

Disk Type in API	Virtual Disk Creation on VMware Host	Filename on Host
MONOLITHIC_SPARSE	In Select A Disk Type, accepting the defaults by not checking any box produces one VMDK file that can grow larger if more space is needed. The <vmname> represents the name of a virtual machine. On VMFS partitions, this is name of the disk descriptor file.	<vmname>.vmdk
MONOLITHIC_FLAT or VMFS_FLAT or VMFS_THIN	If you select only the Allocate all disk space now check box, space is pre-allocated, so the virtual disk cannot grow. The first VMDK file is small and points to a much larger one, whose filename says fLat without a sequence number. Similarly on VMFS partitions, this is the virtual disk file that points to virtual disk data files, either thick or thin provisioned.	<vmname>-flat.vmdk

Table 3-1. VMDK Virtual Disk Files (Continued)

Disk Type in API	Virtual Disk Creation on VMware Host	Filename on Host
SPLIT_SPARSE	If you select only the Split disk into 2GB files check box, virtual disk can grow when more space is needed. The first VMDK file is small and points to a sequence of other VMDK files, all of which have an <i>s</i> before a sequence number, meaning sparse. The number of VMDK files depends on the disk size requested. As data grows, more VMDK files are added in sequence.	<vmname>-s<###>.vmdk
SPLIT_FLAT	If you select the Allocate all disk space now and Split disk into 2GB files check boxes, space is pre-allocated, so the virtual disk cannot grow. The first VMDK file is small and points to a sequence of other files, all of which have an <i>f</i> before the sequence number, meaning flat. The number of files depends on the requested size.	<vmname>-f<###>.vmdk
MONOLITHIC_SPARSE or SPLIT_SPARSE snapshot	A redo log (or child disk or delta link) is created when a snapshot is taken of a virtual machine, or with the virtual disk library. Snapshot file numbers are in sequence, without an <i>s</i> or <i>f</i> prefix. The numbered VMDK file stores changes made to the virtual disk <diskname> since the original parent disk, or previously numbered redo log (in other words the previous snapshot).	<diskname>-<###>.vmdk
SE_SPARSE	Space-efficient sparse (seSparse) format. In vSphere 5.1 and later, used by VMware View to optimize linked clone templates. In the vSphere API, see data object SeSparseVirtualDiskSpec. Use of seSparse as a base disk is neither documented nor supported.	
n/a	Snapshot of a virtual machine, which includes pointers to all its .vmdk virtual disk files.	<vmname>Snapshot.vmsn

For lazy zeroed thick disk, all blocks are allocated, and data written to used blocks, however unused blocks are left as-is, so they may contain data from previous use. Many storage systems will zero-out unused blocks in the background. With eager zeroed thick disk, unused blocks are zeroed-out at allocation time.

Thin Provisioned Disk

With thin provisioned disk, the vSphere Client may report that provisioned size is greater than disk capacity.

Provisioned size for a thin disk is the maximum size the disk will occupy when fully allocated. Actual size is the current size of the thin disk. Overcommit means that if all thin disks were fully provisioned, there would not be enough space to accommodate all of the thin disks.

Internationalization and Localization

VDDK libraries are not localized, but backup partners can support any locale that uses UTF-8 encoding. Other than Unicode, VDDK does not support multibyte character encodings such as Extended Unix Code (EUC) for Chinese, Japanese, and Korean (ISO-2022).

The path name to a virtual machine and its VMDK can be expressed with any character set supported by the host file system. As of vSphere 4 and Workstation 7, VMware supports Unicode UTF-8 path names, although for portability to various locales, ASCII-only path names are recommended.

Windows 2000 systems (and later) use UTF-16 for localized path names. For example, in locale FR (Français) the VDDK sample code might mount disk at C:\Windows\Temp\vmware-Système, where è is encoded as UTF-16 so the VixMntapi library cannot recognize it. In this case, a workaround is to set the `tmpDirectory` configuration key with an ASCII-only path before program start-up; see [Initialize the Library](#).

For programs opening arbitrary path names, Unicode offers a GNU library with C functions `iconv_open()` to initialize codeset conversion, and `iconv()` to convert UTF-8 to UTF-16, or UTF-16 to UTF-8.

Virtual Disk Internal Format

The *Virtual Disk Format 5.0* technical note provides possibly useful information about the VMDK format, and is available at this URL:

http://www.vmware.com/support/developer/vddk/vmdk_50_technote.pdf

Grain Directories and Grain Tables

SPARSE type virtual disks use a hierarchical representation to organize sectors. See *Virtual Disk Format 5.0* referenced in [Virtual Disk Internal Format](#). In this context, grain means granular unit of data, larger than a sector. The hierarchy includes:

- Grain directory (and redundant grain directory) whose entries point to grain tables.
 - Grain tables (and redundant grain tables) whose entries point to grains.
 - Each grain is a block of sectors containing virtual disk data. Default size is 128 sectors or 64KB.

Data Structures in Virtual Disk API

Here are important data structure objects with brief descriptions:

- `VixError` – Error code of type `uint64`.
- `VixDiskLibConnectParams` – Public types designate the virtual machine credentials `vmxSpec` (possibly through vCenter Server), the name of its host, and the credential type for authentication. For details, see [VMX Specification](#). The `credType` can be `VIXDISKLIB_CRED_UID` (user name / password, most common), `VIXDISKLIB_CRED_SESSIONID` (the HTTP session ID), `VIXDISKLIB_CRED_TICKETID` (vSphere ticket ID), or `VIXDISKLIB_CRED_SSPI` (Windows only, current thread credentials).

```
typedef char * vmxSpec
typedef char * serverName
typedef VixDiskLibCredType credType
```

- VDDK 6.7 has a new union in the `VixDiskLibConnectParams` structure; see [First Class Disk \(FCD\) Backup](#).
- `VixDiskLibConnectParams::VixDiskLibCreds` – Credentials for either user ID or session ID.
 - `VixDiskLibConnectParams::VixDiskLibCreds::VixDiskLibUidPasswdCreds` – String data fields represent user name and password for authentication.
 - `VixDiskLibConnectParams::VixDiskLibCreds::VixDiskLibSessionIdCreds` – String data fields represent the session cookie, user name, and encrypted session key.
 - `VixDiskLibConnectParams::VixDiskLibCreds::VixDiskLibSSPICreds` – String data fields for security support provider interface (SSPI) authentication. User name and password are null.
- `VixDiskLibCreateParams` – Types represent the virtual disk (see [Virtual Disk Types](#)), the disk adapter (see [Adapter Types](#)), VMware version, and capacity of the disk sector.

```
typedef VixDiskLibDiskType diskType
typedef VixDiskLibAdapterType adapterType
typedef uint hwVersion
typedef VixDiskLibSectorType capacity
```

- `VixDiskLibDiskInfo` – Types represent the geometry in the BIOS and physical disk, the capacity of the disk sector, the disk adapter (see [Adapter Types](#)), the number of child-disk links (redo logs), and a string to help locate the parent disk (state before redo logs).

```
VixDiskLibGeometry biosGeo
VixDiskLibGeometry physGeo
VixDiskLibSectorType capacity
VixDiskLibAdapterType adapterType
int numLinks
char * parentFileNameHint
```

- `VixDiskLibGeometry` – Types specify virtual disk geometry, not necessarily the same as physical disk geometry.

```
typedef uint32 cylinders
typedef uint32 heads
typedef uint32 sectors
```

Credentials and Privileges for VMDK Access

Local operations are supported by local VMDK. Access to ESXi hosts is authenticated by login credentials, so with proper credentials `VixDiskLib` can reach any VMDK on an ESXi host. VMware vSphere has its own set of privileges, so with the proper privileges (see below) and login credentials, `VixDiskLib` can reach any VMDK on an ESXi host managed by vCenter Server. `VixDiskLib` supports the following:

- Both read-only and read/write modes
- Read-only access to disk associated with any snapshot of online virtual machines

- Access to VMDK files of offline virtual machines (vCenter restricted to registered virtual machines)
- Reading of Microsoft Virtual Hard Disk (VHD) format

With vCenter Server, the Role of the backup appliance when saving data must have these privileges for all the virtual machines being backed up:

- VirtualMachine > Configuration > Disk change tracking
- VirtualMachine > Provisioning > Allow read-only disk access *and* Allow VM download
- VirtualMachine > State > Create snapshot *and* Remove snapshot

On the backup appliance, the user must have the following privileges:

- Datastore > Allocate space
- VirtualMachine > Configuration > Add new disk *and* Remove disk
- VirtualMachine > Configuration > Change resource *and* Settings

The user must have this privilege for vCenter Server and all ESXi hosts involved in backup:

- Global > DisableMethods *and* EnableMethods

If privileges are not applied at the vCenter Server level, the returned error message is somewhat misleading: “The host is not licensed for this feature.”

Adapter Types

The library can select the following adapters:

- VIXDISKLIB_ADAPTER_IDE – Virtual disk acts like ATA, ATAPI, PATA, SATA, and so on. You might select this adapter type when it is specifically required by legacy software.
- VIXDISKLIB_ADAPTER_SCSI_BUSLOGIC – Virtual SCSI disk with Buslogic adapter. This is the default on some platforms and is usually recommended over IDE due to higher performance.
- VIXDISKLIB_ADAPTER_SCSI_LSILOGIC – Virtual SCSI disk with LSI Logic adapter. Windows Server 2003 and most Linux virtual machines use this type by default. Performance is about the same as Buslogic.

Virtual Disk Transport Methods

VMware supports file-based or image-level backups of virtual machines hosted on an ESXi host with SAN or NAS storage. Virtual machines read data directly from a shared VMFS LUN, so backups are efficient and do not put significant load on production ESXi hosts or the virtual network.

VMware offers interfaces for integration of storage-aware applications, including backup, with efficient access to storage clusters. Developers can use VDDK advanced transports, which provide efficient I/O methods to maximize backup performance. VMware supports four access methods: local file, NBD (network block device) over LAN, NBD with SSL encryption (NBDSSL), SAN, and SCSI HotAdd.

Local File Access

The virtual disk library can read virtual disk data from `/vmfs/volumes` on ESXi hosts, or from the local file system on hosted products. This file access method is built into VixDiskLib, so it is always available on local storage. However it is not a network transport method, and is seldom used for vSphere backup.

SAN Transport

SAN mode requires applications to run on a backup server with access to SAN storage (Fibre Channel, iSCSI, or SAS connected) containing the virtual disks to be accessed. As shown in the figure below, this method is efficient because no data needs to be transferred through the production ESXi host. A SAN backup proxy must be a physical machine. If it has optical media or tape drive connected, backups can be made entirely LAN-free.

Figure 3-1. SAN transport mode for backup

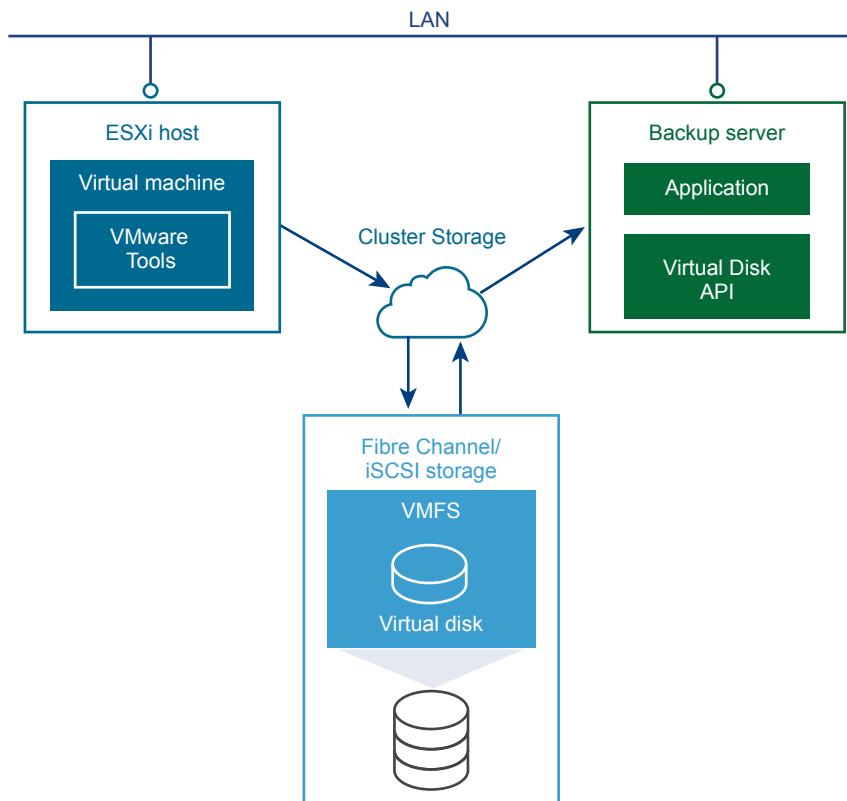

In SAN transport mode, the virtual disk library obtains information from an ESXi host about the layout of VMFS LUNs, and using this information, reads data directly from the storage LUN where a virtual disk resides. This is the fastest transport method for software deployed on SAN-connected ESXi hosts.

In general, SAN transport works with any storage device that appears at the driver level as a LUN (as opposed to a file system such as NTFS or EXT). SAN mode must be able to access the LUN as a raw device. The real key is whether the device behaves like a direct raw connection to the underlying LUN. SAN transport is supported in Fibre Channel, iSCSI, and SAS based storage arrays (SAS means serial attached SCSI). SAN storage devices can contain SATA drives, but currently there are no SATA connected SAN devices on the VMware hardware compatibility list.

SAN transport is not supported for backup or restore of virtual machines residing on VVol datastores.

VMware vSAN, a network based storage solution with direct attached disks, does not support SAN transport. Because vSAN uses modes that are incompatible with SAN transport, if the virtual disk library detects the presence of vSAN, it disables SAN mode. Other advanced transports do work.

HotAdd Transport

HotAdd is a VMware feature where devices can be added “hot” while a virtual machine is running. Besides SCSI disk, virtual machines can add additional CPUs and memory capacity.

HotAdd is a good way to get virtual disk data from a virtual machine to a backup appliance (or backup proxy) for sending to the media server. The attached HotAdd disk is shown in the figure below.

Figure 3-2. HotAdd transport mode for backup

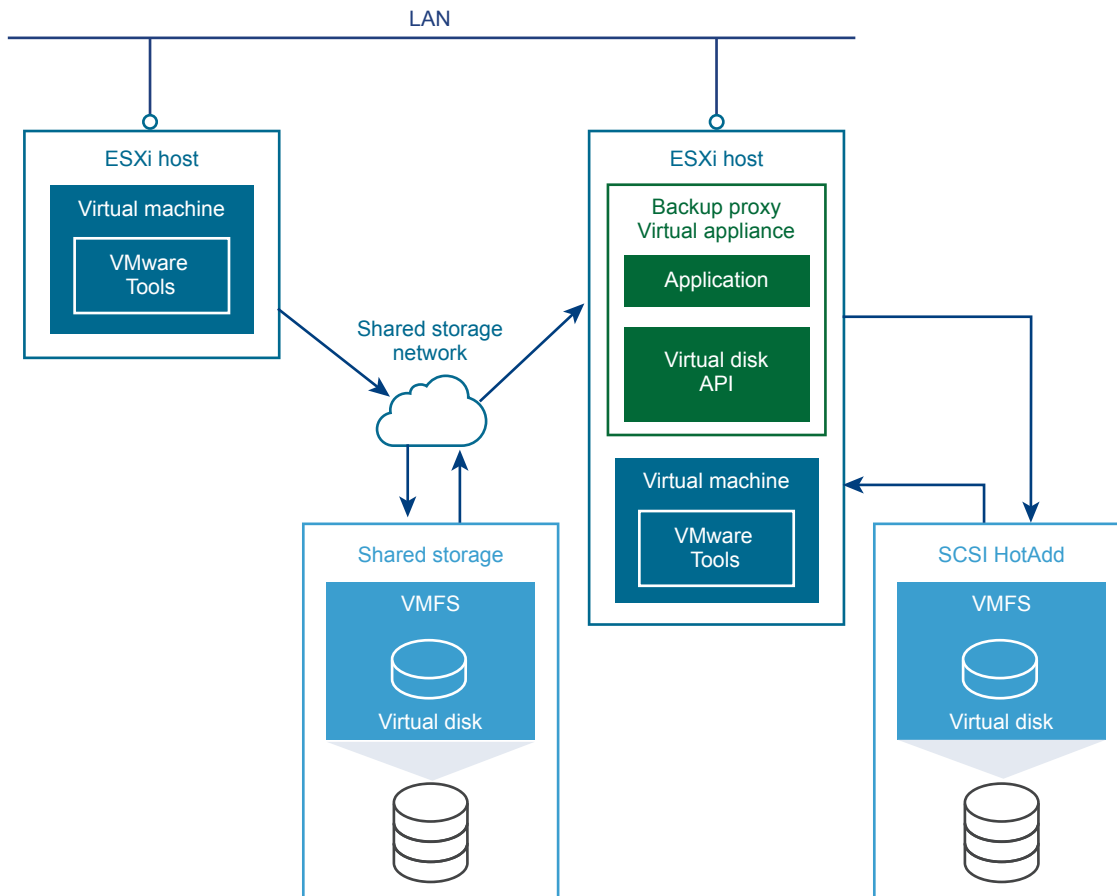

Running the backup proxy as a virtual machine has two advantages: it is easy to move a virtual machine to a new media server, and it can back up local storage without using the LAN, although this incurs more overhead on the physical ESXi host than when using SAN transport mode.

If backup software runs in a virtual appliance, it can take a snapshot and create a linked clone of the target virtual machine, then attach and read the linked clone's virtual disks for backup. This involves a SCSI HotAdd on the ESXi host where the target VM and backup proxy are running. Virtual disks of the linked clone are HotAdded to the backup proxy. The target virtual machine continues to run during backup.

VixTransport handles the temporary linked clone and hot attachment of virtual disks. VixDiskLib opens and reads the HotAdded disks as a "whole disk" VMDK (virtual disk on the local host). This strategy works only on virtual machines with SCSI disks and is not supported for backing up virtual IDE disks. HotAdd transport also works with virtual machines stored on NFS partitions.

About the HotAdd Proxy

The HotAdd backup proxy must be a virtual machine. HotAdd involves attaching a virtual disk to the backup proxy, like attaching disk to a virtual machine. In typical implementations, a HotAdd proxy backs up either Windows or Linux virtual machines, but not both. For parallel backup, sites can deploy multiple proxies.

The HotAdd proxy must have access to the same datastore as the target virtual machine, and the VMFS version and data block sizes for the target VM must be the same as the datastore where the HotAdd proxy resides.

If the HotAdd proxy is a virtual machine that resides on a VMFS-3 volume, choose a volume with block size appropriate for the maximum virtual disk size of virtual machines that customers want to back up, as shown in [Table 3-2](#). This caveat does not apply to VMFS-5 volumes, which always have 1MB file block size. As of vSphere 6.7, VMFS-3 is no longer supported.

Table 3-2. VMFS-3 Block Size for HotAdd Backup Proxy

VMFS-3 Block Size	Maximum Target Disk Size
1MB (also for VMFS-5)	256GB (as of vSphere 5.5, 62TB)
2MB	512GB
4MB	1024GB
8MB	2048GB

NBDSSL Transport

When no other transport is available, networked storage applications can use LAN transport for data access, with NBD (network block device) protocol, optionally with SSL encryption, called NBDSSL. NBD is a Linux-style kernel module that treats storage on a remote host as a block device. NBDSSL is a VMware variant that uses SSL to encrypt all data passed over the TCP connection. The NBDSSL transport method is built into the virtual disk library, so it is always available, and is the fall-back when no other transport method is available.

VMware libraries often fall back to NBDSSL when other transports are not available. Backup applications can select NBD for higher throughput.

Figure 3-3. NBDSSL transport mode for backup

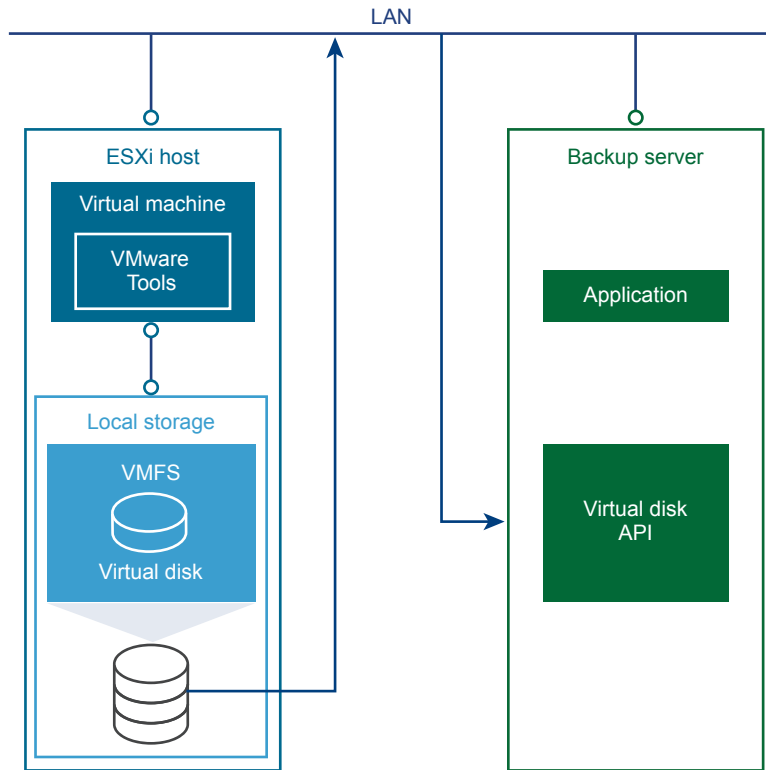

In this mode, the ESXi host reads data from storage and sends it across a network to the backup server. With LAN transport, large virtual disks can take a long time to transmit. This transport mode adds traffic to the LAN, unlike SAN and HotAdd transport, but NBDSSL transport offers the following advantages:

- The ESXi host can use any storage device, including local storage or remote-mounted NAS.
- The backup proxy can be a virtual machine, so customers can use vSphere resource pools to minimize the performance impact of backup. For example, the backup proxy can be in a lower-priority resource pool than the production ESXi hosts.

When VDDK opens a non-snapshot disk for NBDSSL transfer (read-only or read/write) it selects the ESXi host where the disk's virtual machine currently resides.

However when VDDK opens a snapshot for NBDSSL transfer, the common backup case, VDDK passes the datastore to vCenter Server, which consults its list of ESXi hosts with access to the datastore; vCenter picks the first host with read/write access. The list of hosts is unordered, so the host chosen for NBDSSL transfer of the snapshot is not necessarily the ESXi host where the snapshot's virtual machine resides.

NBDSSL Performance

When reading disk data using NBDSSL transport, VDDK makes synchronous calls. That is, VDDK requests a block of data and waits for a response. The block is read from disk and copied into a buffer on the server side, then sent over the network. Meanwhile, no data gets copied over the network, adding to wait time. To some extent, you can overcome this limitation by using multiple streams to simultaneously read from a single disk or multiple disks, taking advantage of parallelism.

As of vSphere 6.5, NBDSSL performance can be significantly improved using data compression. Three types are available – `zlib`, `fastlz`, and `skipz` – specified as flags when opening virtual disks with the extended `VixDiskLib_Open()` call. See [Open a Local or Remote Disk](#).

Asynchronous Mode NBDSSL

As of vSphere 6.7, asynchronous I/O for NBDSSL transport mode is available. Performance of NBDSSL mode data transfer can be improved with this option.

To implement asynchronous NBDSSL, use the new functions `VixDiskLib_ReadAsync` and `VixDiskLib_WriteAsync` in a callback, followed by `VixDiskLib_Wait`, to replace the `VixDiskLib` read and write functions. In the development kit, see `vixDiskLibSample.cpp` for code examples, following logic for the `-readasyncbench` and `-writeasyncbench` options.

VDDK has had non-public asynchronous APIs since VDDK 6.0, but behavior is different in earlier releases. File transport mode is synchronous in all releases.

Table 3-3. Asynchronous read and write

	VDDK 6.0	VDDK 6.5	6.7
<code>VixDiskLib_ReadAsync</code>	Always synchronous.	Same as 6.0.	For HotAdd and SAN modes, same as 6.0 and 6.5. NBDSSL mode is asynchronous if the ESXi host supports asynchronous NBD.
<code>VixDiskLib_WriteAsync</code>	For HotAdd and NBDSSL modes, always synchronous. For SAN mode, the API is asynchronous. A thread handles writes one by one in the back-end, so outstanding I/O is always 1.	Same as 6.0.	For HotAdd and SAN modes, same as 6.0 and 6.5. NBDSSL mode is asynchronous if the ESXi host supports asynchronous NBD, as does ESXi 6.7.

NFC Session Limits and Timeouts

NBDSSL employs the network file copy (NFC) protocol. [Table 3-4](#) shows limits on the number of connections for various host types. These are host limits, not per process limits. Additionally vCenter Server imposes a limit of 52 connections. `VixDiskLib_Open()` uses one connection for every virtual disk that it accesses on an ESXi host. Clone with `VixDiskLib_Clone()` also requires a connection. It is not possible to share a connection across physical disks. These NFC session limits do not apply to SAN or HotAdd transport.

Table 3-4. NFC Session Connection Limits

Host Platform	When Connecting	Limits You To About
vSphere 3.5	to an ESX host	9 connections directly, 27 connections through vCenter Server
vSphere 4.x	to an ESXi host	11 connections directly, 23 connections through vCenter Server
vSphere 5.x	to an ESXi host or vCenter Server	Limited by a transfer buffer for all NFC connections, enforced by the host; the sum of all NFC connection buffers to an ESXi host cannot exceed 32MB. 52 connections through vCenter Server, including the above per-host limit.
vSphere 6.x	to an ESXi host or vCenter Server	The sum of all NFC connection buffers cannot exceed 48MB by default. ESXi host'd limit can be changed with <code>config.xml</code> but vCenter is not configurable. With 1MB buffers per I/O stream, 48 requests can be concurrent.

The `InitEx` configuration file parameter `vixDiskLib.nfc.ReadTimeoutMs` indicates the preferred connection timeout for backup and restore operations, and has the effect of influencing TCP keep-alive time when no reads occur, which they do not during prolonged restores. If the `ReadTimeoutMs` value is set higher than the TCP keep-alive time on the network, then a connection timeout could occur.

For example, if the configuration file sets `ReadTimeoutMs` flag to 3600000 milliseconds (60 minutes) instead of accepting the default (varies from 6 to 45 seconds) then a TCP keep-alive packet transmits only after 60 minutes. If restoring a virtual disk takes longer, leaving network read activity idle for 60 minutes, the connection could break so subsequent restores fail.

SSL Certificates and Security

The VDDK 5.1 release and later were security hardened, with virtual machines set to check SSL certificates.

On Windows VDDK 5.1 and 5.5 required the `VerifySSLCertificates` and `InstallPath` registry keys under `HKEY_LOCAL_MACHINE\SOFTWARE` to check SSL certificates. On Linux VDDK 5.1 and 5.5 required adding a line to the `VixDiskLib_InitEx` configuration file to set `linuxSSL.verifyCertificates = 1`.

As of VDDK 6.0 both SSL certificate verification and SSL thumbprint checking are mandatory and cannot be disabled. The Windows registry and Linux SSL setting are no longer checked, so neither has any effect.

Specifically VDDK 6.0 and later use X.509 certificates with TLS cryptography, replacing SSLv3.

The following library functions enforce SSL certificate checking: `InitEx`, `PrepareForAccess`, `EndAccess`, `GetNfcTicket`, and the `GetRpcConnection` interface that is used by all advanced transports. SSL verification may use thumbprints to check if two certificates are the same. The vSphere thumbprint is a cryptographic hash of a certificate obtained from a trusted source such as vCenter Server, and passed in the `SSLVerifyParam` structure of the NFC ticket.

4

Virtual Disk API Functions

This chapter provides an overview of functions in the Virtual Disk API and includes the following sections:

After a presentation of Virtual Disk API functions in alphabetic order, sections focus on what the functions do, in the normal order they would appear in a program, except advanced transport functions (SAN and HotAdd) appear after the shutdown functions.

This chapter includes the following topics:

- [Virtual Disk Library Functions](#)
- [Start Up](#)
- [Disk Operations](#)
- [Metadata Handling](#)
- [Disk Chaining and Redo Logs](#)
- [Cloning a Virtual Disk](#)
- [Error Handling](#)
- [Administrative Disk Operations](#)
- [Shut Down](#)
- [Advanced Transport APIs](#)
- [Ordering of Function Calls in Sequence](#)
- [Updating Applications for Advanced Transport](#)
- [Multithreading Considerations](#)
- [Capabilities of Library Calls](#)

Virtual Disk Library Functions

You can find the *VixDiskLib API Reference* by using a Web browser to open the `doc/index.html` file in the VDDK software distribution. As in most reference manuals, functions are organized alphabetically, whereas in this chapter, functions are ordered by how they might be called.

When the API reference says that a function supports “only hosted disks,” it means virtual disk images hosted by VMware Workstation or similar products. Virtual disk stored on VMFS partitions managed by ESXi or vCenter Server is called “managed disk.”

The functions described in this chapter are based on concepts and employ data structures documented in [Chapter 3 Virtual Disk Interfaces](#).

If the library accesses virtual disk on VMFS, I/O by default goes through the ESXi host, which manages physical disk storage. To use function calls that provide direct access to SAN storage, start your program by calling the `VixDiskLib_ConnectEx()` function, as described in [Advanced Transport APIs](#).

Alphabetic Table of Functions

Function calls in the Virtual Disk API are listed alphabetically in [Table 4-1](#).

Table 4-1. Virtual Disk API Functions

Function	Description
<code>VixDiskLib_Attach</code>	Attach the child disk chain to the parent disk chain.
<code>VixDiskLib_Cleanup</code>	Remove leftover transports. See Clean Up After Disconnect .
<code>VixDiskLib_Clone</code>	Copy virtual disk to some destination, converting formats as appropriate.
<code>VixDiskLib_Close</code>	Close an open virtual disk. See Close a Local or Remote Disk .
<code>VixDiskLib_Connect</code>	Connect to the virtual disk library to obtain services. See also <code>ConnectEx</code> .
<code>VixDiskLib_ConnectEx</code>	Connect to optimum transport. See Connect to VMware vSphere
<code>VixDiskLib_Create</code>	Create a virtual disk according to specified parameters.
<code>VixDiskLib_CreateChild</code>	Create a child disk (redo log or delta link) for a hosted virtual disk.
<code>VixDiskLib_Defragment</code>	Defragment the sectors of a virtual disk.
<code>VixDiskLib_Disconnect</code>	Disconnect from the library. See Disconnect from Server .
<code>VixDiskLib_EndAccess</code>	Notify a host that it may again relocate a virtual machine. See Prepare For Access and End Access .
<code>VixDiskLib_Exit</code>	Release all resources held by the library. See Clean Up and Exit .
<code>VixDiskLib_Flush</code>	Flush asynchronous write data to disk. Replaced by <code>wait</code> function.
<code>VixDiskLib_FreeErrorText</code>	Free the message buffer allocated by <code>GetErrorText</code> .
<code>VixDiskLib_FreeInfo</code>	Free the memory allocated by <code>GetInfo</code> .
<code>VixDiskLib_GetErrorText</code>	Return the text description of a library error code.
<code>VixDiskLib_GetInfo</code>	Retrieve information about a virtual disk.
<code>VixDiskLib_GetMetadataKeys</code>	Retrieve all keys in the metadata of a virtual disk.
<code>VixDiskLib_GetTransportMode</code>	Get the current transport mode. See Get Selected Transport Method .
<code>VixDiskLib_Grow</code>	Increase size of an existing virtual disk.
<code>VixDiskLib_Init</code>	Initialize the old virtual disk library. Replaced by <code>InitEx</code> function.
<code>VixDiskLib_InitEx</code>	Initialize new virtual disk library. See Initialize Virtual Disk API .
<code>VixDiskLib_ListTransportModes</code>	Available transport modes. See List Available Transport Methods .
<code>VixDiskLib_Open</code>	Open a virtual disk. See Open a Local or Remote Disk .

Table 4-1. Virtual Disk API Functions (Continued)

Function	Description
VixDiskLib_PrepareForAccess	Notify a host to refrain from relocating a virtual machine. See Prepare For Access and End Access .
VixDiskLib_Read	Read from an open virtual disk. See Read Sectors From a Disk .
VixDiskLib_ReadAsync	Asynchronously read a range of sectors.
VixDiskLib_ReadMetadata	Retrieve the value of a given key from disk metadata.
VixDiskLib_Rename	Change the name of a virtual disk.
VixDiskLib_Shrink	Reclaim blocks of zeroes from the virtual disk.
VixDiskLib_SpaceNeededForClone	Compute the space required to clone a virtual disk, in bytes.
VixDiskLib_Unlink	Delete the specified virtual disk.
VixDiskLib_Wait	Wait for all asynchronous operations to complete.
VixDiskLib_Write	Write to an open virtual disk. See Write Sectors To a Disk .
VixDiskLib_WriteAsync	Asynchronously write a range of sectors.
VixDiskLib_WriteMetadata	Update virtual disk metadata with the given key/value pair.

Start Up

The `VixDiskLib_Init()` and `VixDiskLib_Connect()` functions must appear in all virtual disk programs.

`VixDiskLib_Init()` has been superseded by `VixDiskLib_InitEx()`. See [Initialize Virtual Disk API](#).

Initialize the Library

`VixDiskLib_Init()` initializes the old virtual disk library. The arguments `majorVersion` and `minorVersion` represent the VDDK library's release number and dot-release number. The optional third, fourth, and fifth arguments specify log, warning, and panic handlers. DLLs and shared objects may be located in `libDir`.

```
VixError vixError = VixDiskLib_Init(majorVer, minorVer, &logFunc, &warnFunc, &panicFunc, libDir);
```

You should call `VixDiskLib_Init()` only once per process because of internationalization restrictions, at the beginning of your program. You should call `VixDiskLib_Exit()` at the end of your program for cleanup. For multithreaded programs you should write your own `logFunc` because the default function is not thread safe.

In most cases you should replace `VixDiskLib_Init()` with `VixDiskLib_InitEx()`, which allows you to specify a configuration file. For information about `InitEx`, see [Initialize Virtual Disk API](#).

Connect to a Workstation or Server

`VixDiskLib_Connect()` connects the library to either a local VMware host or a remote server. For hosted disk on the local system, provide null values for most connection parameters. For managed disk on vSphere, specify virtual machine name, vCenter Server or ESXi host, user name, password, and port number.

```
vixError = VixDiskLib_Connect(&cnxParams, &srcConnection)
```

Always call `VixDiskLib_Disconnect()` before the end of your program.

Calling `vixDiskLib_Disconnect()` invalidates any open file handles, so if you use the `VixMntapi` library, call `VixMntApi_CloseDiskSet()` before calling disconnect.

You can opt to use the `VixDiskLibSSPICreds` connection parameter to enable Security Support Provider Interface (SSPI) authentication. SSPI has the advantage of not storing plain text passwords in configuration files or in the registry. In order to be able to use SSPI, the following conditions must be met:

- Connections must be made directly to a vCenter Server instance.
- Applications and their connections must employ one of two user account arrangements. The connection must be established either using the same user context with the same user name and password credentials on both the proxy and the vSphere Server, or using a domain user. Attempts by applications to establish connections using the Local System account context will fail.
- User contexts must have administrator privileges on the proxy and have VCB Backup User role assigned in vSphere (by the vCenter Server).

If your setup meets all these conditions, you can enable SSPI authentication by setting `USERNAME` to `__sspi__`. For SSPI, the password must be set, but it is ignored. It can be set to `""` (null string).

VMX Specification

On VMware platform products, `.vmx` is a text file (usually located in the same directory as virtual disk files) specifying virtual machine configuration. The Virtual Machine eXecutable (VMX) process is the user-space component (or “world”) of a virtual machine. The virtual disk library connects to virtual machine storage through the VMX process.

When specifying connection parameters (see [Data Structures in Virtual Disk API](#)) the preferred syntax for `vmxSpec` is as follows:

- Managed object reference of the virtual machine, an opaque object that you obtain programmatically using the `PropertyCollector` managed object:

```
moRef=<moref-of-vm>
```

The moRef of a virtual machine or disk snapshot on an ESXi host is likely different than the moRef of the same virtual machine or disk snapshot as managed by vCenter Server. Here are two example moRef specifications, one for ESXi and one for vCenter Server, both referring to the same snapshot:

```
moref=153
moref=271
```

Disk Operations

These functions create, open, read, write, query, and close virtual disk.

Create a New Hosted Disk

VixDiskLib_Create() locally creates a new virtual disk, after being connected to the host. In createParams, you must specify the disk type, adapter, hardware version, and capacity as a number of sectors. This function supports hosted disk. For managed disk, first create a hosted type virtual disk, then use VixDiskLib_Clone() to convert the virtual disk to managed disk.

```
vixError =
VixDiskLib_Create(appGlobals.connection, appGlobals.diskPath, &createParams, NULL, NULL);
```

Currently VixDiskLib_Create() enforces a 4GB limit for virtual disks on FAT32 and FAT file systems, a 16TB - 54KB (hex FFFFFFFF0000) limit on NTFS file systems, and a $2^{64} - 1$ limit (more than an exabyte) on ReFS and exFAT file systems. Hosted virtual disk > 2TB is not supported.

POSIX based file systems including NFS version 3 no longer have a 2GB file size limit. Although various checks are done to avoid creating impossibly large files, it becomes the customer's responsibility to cope with 2GB limits on NFS version 2 or Linux kernel 2.4 (EFS).

Open a Local or Remote Disk

After the library connects to a workstation or server, VixDiskLib_Open() opens a virtual disk. With SAN or HotAdd transport, opening a remote disk for writing requires a pre-existing snapshot.

```
vixError =
VixDiskLib_Open(appGlobals.connection, appGlobals.diskPath, appGlobals.openFlags, &srcHandle);
```

The following flags modify the open instruction:

- VIXDISKLIB_FLAG_OPEN_UNBUFFERED – Disable host disk caching.
- VIXDISKLIB_FLAG_OPEN_SINGLE_LINK – Open the current link, not the entire chain (hosted disk only).
- VIXDISKLIB_FLAG_OPEN_READ_ONLY – Open the virtual disk read-only.

As of vSphere 6.5, the following additional flags are available:

- VIXDISKLIB_FLAG_OPEN_COMPRESSION_ZLIB – Open for NBDSSL transport, zlib compression.

- VIXDISKLIB_FLAG_OPEN_COMPRESSION_FASTLZ – Open for NBDSSL transport, fastlz compression.
- VIXDISKLIB_FLAG_OPEN_COMPRESSION_SKIPZ – Open for NBDSSL transport, skipz compression.

Read Sectors From a Disk

VixDiskLib_Read() reads a range of sectors from an open virtual disk. You specify the beginning sector and the number of sectors. Sector size could vary, but is defined in <vixDiskLib.h> as 512 bytes because VMDK files have that sector size.

```
vixError = VixDiskLib_Read(srcHandle, i, j, buf);
```

In vSphere 6.7 and later, you can improve performance of NBD transport with asynchronous reads. Asynchronous calls may be used for all transport modes, because they fall back to synchronous as needed.

```
// customized callback for complete notification
void myDiskLibCompletion(void *cbData, VixError result);
// a loop for multiple read requests
for (...)
    vixError = VixDiskLib_ReadAsync(srcHandle, i, j, buf, myDiskLibCompletion, cbData);
    if (vixError != VIX_ASYNC) {
        // handle error
    }
}
VixDiskLib_Wait(srcHandle); // wait for all async read to complete
```

Write Sectors To a Disk

VixDiskLib_Write() writes one or more sectors to an open virtual disk. This function expects the fourth parameter buf to be VIXDISKLIB_SECTOR_SIZE bytes long.

```
vixError = VixDiskLib_Write(newDisk.Handle(), i, j, buf);
```

In vSphere 6.7 and later, you can improve performance of NBD transport with asynchronous writes. Your program VixDiskLib_WriteAsync in a loop, then calls VixDiskLib_Wait to let all asynchronous writes complete.

```
// customized callback for complete notification
void myDiskLibCompletion(void *cbData, VixError result);
// a loop for multiple write requests
for (...)
    vixError = VixDiskLib_WriteAsync(newDisk.Handle(), i, j, buf, myDiskLibCompletion, cbData);
    if (vixError != VIX_ASYNC) {
        // handle error
    }
}
VixDiskLib_Wait(newDisk.Handle()); // wait for async write to complete
```

Close a Local or Remote Disk

`VixDiskLib_Close()` closes an open virtual disk.

```
VixDiskLib_Close(srcHandle);
```

`VixDiskLib_Close()` returns `VIX_OK` if successful, otherwise a suitable error code. To obtain a list of possible return codes, see [Finding Error Code Documentation](#).

If a program has worker threads called from a master process, errors might occur in the threads after the master process calls `VixDiskLib_Close()`. Always wait for worker threads to end before calling close.

Get Information About a Disk

```
vixError = VixDiskLib_GetInfo(srcHandle, diskInfo);
```

`VixDiskLib_GetInfo()` gets data about an open virtual disk, allocating a filled-in `VixDiskLibDiskInfo` structure. Some of this information overlaps with metadata (see [Metadata Handling](#)).

Free Memory from Get Information

This function deallocates memory allocated by `VixDiskLib_GetInfo()`. Call it to avoid a memory leak.

```
vixError = VixDiskLib_FreeInfo(diskInfo);
```

Metadata Handling

VMware provides mechanisms for reading, writing, and repairing virtual disk metadata.

Read Metadata Key from Disk

```
vixError = VixDiskLib_ReadMetadata(disk.Handle(), appGlobals.metaKey, &val[0], requiredLen, NULL);
```

Retrieves the value of a given key from disk metadata. The metadata for a hosted VMDK is not as extensive as for managed disk on an ESXi host. Held in a mapping file, VMFS metadata might also contain information such as disk label, LUN or partition layout, number of links, file attributes, locks, and so forth. Metadata also describes encapsulation of raw disk mapping (RDM) storage, if applicable.

Get Metadata Table from Disk

`VixDiskLib_GetMetadataKeys()` retrieves all existing keys from the metadata of a virtual disk, but not the key values. Use this in conjunction with `VixDiskLib_ReadMetadata()`.

```
vixError = VixDiskLib_GetMetadataKeys(disk.Handle(), &buf[0], requiredLen, NULL);
```

Here is an example of a simple metadata table. Uuid is the universally unique identifier for the virtual disk.

```
adapterType = buslogic
geometry.sectors = 32
geometry.heads = 64
geometry.cylinders = 100
uuid = 60 00 C2 93 7b a0 3a 03-9f 22 56 c5 29 93 b7 27
```

Write Metadata Table to Disk

`VixDiskLib_WriteMetadata()` updates virtual disk metadata with the given key-value pair. If the key-value pair is new, it gets added. If the key already exists, its value is updated. A key can be zeroed but not deleted.

```
vixError = VixDiskLib_WriteMetadata(disk.Handle(), appGlobals.metaKey, appGlobals.metaVal);
```

Check and Repair Sparse Disk Metadata

`VixDiskLib_CheckRepair()` checks the metadata of a sparse disk, specified as a file on a connection, and optionally repairs the metadata if necessary. Sparse disks occupy space on a datastore only when a portion of the disk is used; the metadata tracks which portions are allocated.

```
vixError = VixDiskLib_CheckRepair(appGlobals.connection, appGlobals.diskPath, TRUE);
```

Disk Chaining and Redo Logs

In VMDK terminology, all the following are synonyms: child disk, redo log, and delta link. From the original parent disk, each child constitutes a redo log pointing back from the present state of the virtual disk, one step at a time, to the original. This pseudo equation represents the relative complexity of backups and snapshots:

backup image < child disk = redo log = delta link < snapshot

A backup image is less than a child disk because a backup image is merely a data stream. A snapshot is more than a child disk because it contains virtual machine state, with pointers to associated file states on VMDK.

There exist other types of redo logs, such as those that perform progressive protection in vSphere Replication (VR). For disk chaining, the “redo” terminology is especially appropriate for the snapshot revert operation, when changed blocks in the redo log are applied to the base disk, before deleting the redo log. Afterwards the base disk contains a “redo” of all changes that the virtual machine made while the snapshot was active.

Create Child from Parent Disk

Usually you create the first child disk from the parent and create successive children from the latest one in the chain. The disk tracks, in SPARSE format, any disk sectors changed since inception, as illustrated below.

Figure 4-1. Child disks created from parent

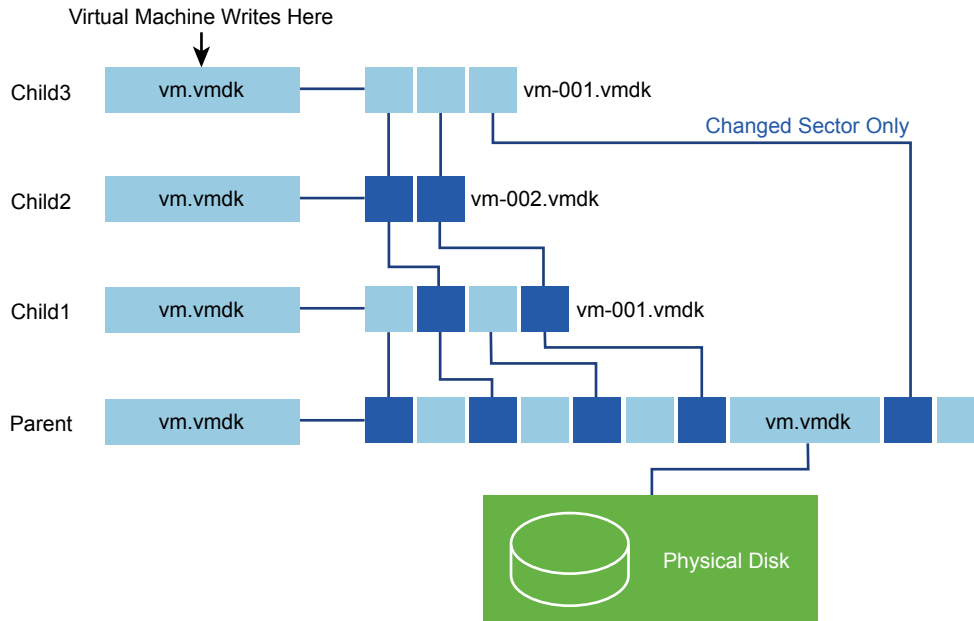

`VixDiskLib_CreateChild()` creates a child disk (or redo log) for a hosted virtual disk. After you create a child, it is generally not necessary to open the parent, or earlier children in the disk chain. The children's `vm.vmdk` files point to redo logs, not to the parent disk, `vm-flat.vmdk` in this example. To access the original parent, or earlier children in the chain, you can use `VixDiskLib_Attach()` on hosted disk.

```
vixError = VixDiskLib_CreateChild(parent.Handle(), appGlobals.diskPath,
    VIXDISKLIB_DISK_MONOLITHIC_SPARSE, NULL, NULL);
```

Attach Child to Parent Disk

`VixDiskLib_Attach()` attaches the child disk into its parent disk chain. Afterwards, the parent handle is invalid and the child handle represents the combined disk chain of redo logs. On failure (`vixError != VIX_OK`) the parent handle is also invalid, so do not close it.

```
vixError = VixDiskLib_Attach(parent.Handle(), child.Handle());
```

For example, suppose you want to access the older disk image recorded by Child1. Attach the handle of new Child1a to Child1, which provides Child1a's parent handle, as shown below. It is now permissible to open, read, and write the Child1a virtual disk.

The parent-child disk chain is efficient in terms of storage space, because the child VMDK records only the sectors that changed since the last `VixDiskLib_CreateChild()`. The parent-child disk chain also provides a redo mechanism, permitting programmatic access to any generation with `VixDiskLib_Attach()`.

Figure 4-2. Child disk attached to disk chain

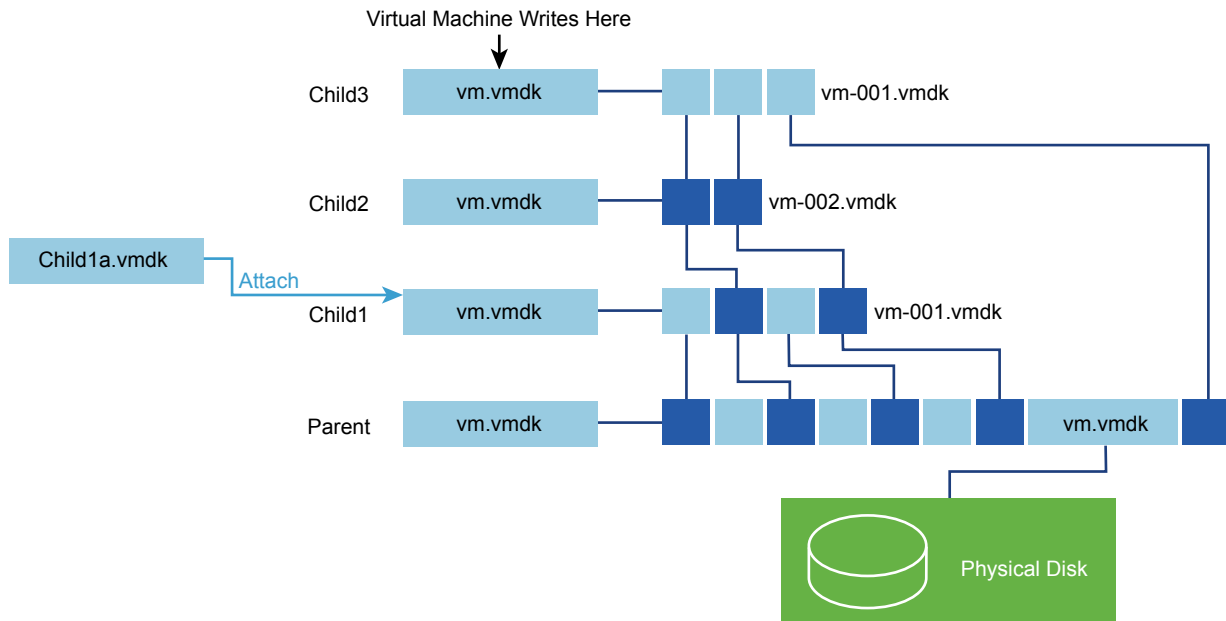

Before VDDK 6.7.1 it was an error to close `parentHandle` after `VixDiskLib_Attach` succeeds. The VDDK library now marks `parentHandle` internally to prevent closure and ensure cleanup. Here is the calling sequence for open and attach:

- 1 Open the disk for attach.
- 2 Create a local connection.
- 3 With backed-up disk (referred to as the parent disk) still open, create child disk with a unique name.
- 4 Open uniquely named `tmp.vmdk` (referred to as the redo log).
- 5 Attach the redo log to its parent disk.

```
VixDiskLib_Open(remoteConnection, virtualDiskPath, flags, &parentHandle);
VixDiskLib_Connect(NULL, &localConnection);
VixDiskLib_CreateChild(parentHandle, "C:\\tmp.vmdk", VIXDISKLIB_DISK_MONOLITHIC_SPARSE, NULL, NULL);
VixDiskLib_Open(localConnection, "C:\\tmp.vmdk", VIXDISKLIB_FLAG_OPEN_SINGLE_LINK, &redoHandle);
VixDiskLib_Attach(parentHandle, redoHandle);
```

Here is the calling sequence for close:

- 1 Close the redo log. Whether to close the parent disk handle is release dependent.

2 Unlink the redo log to detach it from the parent disk.

```
VixDiskLib_Close(redoHandle);
if (VIXDISKLIB_VERSION_MAJOR > 7) {
    VixDiskLib_Close(parentHandle); // to avoid memory leaks
}
VixDiskLib_Unlink(localConnection, "C:\tmp.vmdk");
```

Opening in a Chain

With (parent) base disk B and children C0, C1, and C2, opening C2 gives you the contents of B + C0 + C1 + C2 (not really addition linked data sectors), while opening C1 gives you the contents of B + C0 + C1.

A better solution than recording base disks and which children are descended from which is changed block tracking, `QueryChangedDiskAreas` in the vSphere API. See [Algorithm for vSphere Backup](#).

Redo Logs and Linked Clone Backup

For managed virtual disk on vSphere, snapshots are used primarily for saving system state and for backup, while linked clones create duplicate images for provisioning of View desktops. A snapshot is usually a single redo log in a parent-child chain, while linked clones are usually multiple redo logs based on the same parent.

In the vSphere 5.5 release and later, handling of linked clone hierarchies was changed to improve the efficiency of backup and restore. The disk object now contain a “disk backing” that contains one or more parent backing objects until the base disk is reached. This allows access anywhere in the parent-child disk chain. With a clean never-used base virtual machine, the linked clone hierarchy or snapshot chain always has the proper number of parent backing objects for the nodes in the chain.

VDDK does not contain any convenience interfaces for backing up and restoring the linked clone hierarchy (or the snapshot chain). Backup applications are responsible for discovering and saving the hierarchy if they want to support this as a feature. Linked clones cannot be restored using SAN transport.

In VMware View (VDI) environments, linked clone backup might not be necessary or advisable, especially for nonpersistent desktops that revert to default after use.

When the base disk or a child disk has an extra snapshot, when redo logs used to create linked clones were never deleted, or when any parent or child in the chain needs disk consolidation or is in a bad snapshot state, it is possible to have extra (too many) parent backing objects. Consequently, restore applications should never assume the correct number of parent backing objects. They must recursively query until the base parent backing object is reached, and make sure when restoring leaf nodes that the correct parent backing object matches the node being restored.

Cloning a Virtual Disk

On ESXi hosts in vSphere, programs cannot create managed disk, but they can call `vixDiskLib_Clone()` to convert hosted disk to managed disk.

Compute Space Needed for Clone

This function computes the space required (in bytes) to clone a virtual disk, after possible format conversion.

```
vixError = VixDiskLib_SpaceNeededForClone(child.Handle(), VIXDISKLIB_DISK_VMFS_FLAT, &spaceReq);
```

Caution `VixDiskLib_SpaceNeededForClone()` might not give accurate results, or could return `VIX_E_INVALID_ARG`, when used with thin provisioned disk type `VIXDISKLIB_DISK_VMFS_THIN`.

Clone a Disk by Copying Data

This function copies data from one virtual disk to another, converting (disk type, size, hardware) as specified.

```
vixError = VixDiskLib_Clone(appGlobals.connection, appGlobals.diskPath, srcConnection,
    appGlobals.srcPath, &createParams, CloneProgressFunc, NULL, TRUE);
```

Due to a vSphere 6.5 security enhancement, `VixDiskLib_Clone()` can no longer clone local disks to remote disks that do not belong to any VM. Previous releases allowed use of a retained username and password, but now enhanced security verification is required. The procedure for `VixDiskLib_Clone()` to make a remote connection is first to get an NFC ticket from the ESXi host based on the MoRef of the VM that manages the cloned-to disks. Then build an authenticated NFC connection to the host using that ticket. The MoRef of the VM must be specified in `vmxSpec` of the remote connection parameter passed to `VixDiskLib_Clone()`. The VM must be powered off, and the target disks must already exist before cloning, not necessarily with the same names. Afterwards the VM may be removed from the inventory with `UnregisterVM`, but it must remain on the datastore with its cloned virtual disks.

Error Handling

These functions enhance the usefulness of error messages.

Return Error Description Text

`VixDiskLib_GetErrorText()` returns the textual description of a numeric error code.

```
char* msg = VixDiskLib_GetErrorText(errCode, NULL);
```

Free Error Description Text

`VixDiskLib_FreeErrorText()` deallocates space associated with the error description text.

```
VixDiskLib_FreeErrorText(msg);
```

Administrative Disk Operations

These functions rename, grow, defragment, shrink, and remove virtual disk.

Rename an Existing Disk

`VixDiskLib_Rename()` changes the name of a virtual disk. Use this function only when the virtual machine is powered off.

```
vixError = VixDiskLib_Rename(oldGlobals.diskPath, newGlobals.diskPath);
```

Grow an Existing Local Disk

`VixDiskLib_Grow()` extends an existing virtual disk by adding sectors. This function supports hosted disk, but not managed disk.

```
vixError =
VixDiskLib_Grow(appGlobals.connection, appGlobals.diskPath, size, FALSE, GrowProgressFunc, NULL);
```

Defragment an Existing Disk

`VixDiskLib_Defragment()` defragments an existing virtual disk. Defragmentation is effective with SPARSE type files, but might not do anything with FLAT type. In either case, the function returns `VIX_OK`. This function supports hosted disk, but not managed disk.

```
vixError = VixDiskLib_Defragment(disk.Handle(), DefragProgressFunc, NULL);
```

Defragment consolidates data in the 2GB extents, moving data to lower-numbered extents, and is independent of defragmentation tools in the guest OS, such as Disk > Properties > Tools > Defragmentation in Windows, or the `defrag` command for the Linux Ext2 file system.

VMware recommends defragmentation from the inside out: first within the virtual machine, then using this function or a VMware defragmentation tool, and finally within the host operating system.

Shrink an Existing Local Disk

`VixDiskLib_Shrink()` reclaims unused space in an existing virtual disk, unused space being recognized as blocks of zeroes. This is more effective (gains more space) with SPARSE type files than with pre-allocated FLAT type. On success, the function returns `VIX_OK`. This function supports hosted disk, but not managed disk.

```
vixError = VixDiskLib_Shrink(disk.Handle(), ShrinkProgressFunc, NULL);
```

In VMware system utilities, “prepare” zeros out unused blocks in the VMDK so “shrink” can reclaim them. In the API, use `VixDiskLib_Write()` to zero out unused blocks, and `VixDiskLib_Shrink()` to reclaim space. Shrink does not change the virtual disk capacity, but it makes more space available.

Unlink Extents to Remove Disk

`VixDiskLib_Unlink()` deletes all extents of the specified virtual disk, which unlinks (removes) the disk data. This is similar to the remove or erase command in a command tool.

```
vixError = VixDiskLib_Unlink(appGlobals.connection, appGlobals.diskPath);
```

Shut Down

All Virtual Disk API applications should call these functions at end of program.

Disconnect from Server

`VixDiskLib_Disconnect()` breaks an existing connection.

```
VixDiskLib_Disconnect(srcConnection);
```

Clean Up and Exit

`VixDiskLib_Exit()` cleans up the library before exit.

```
VixDiskLib_Exit();
```

Advanced Transport APIs

For managed disk, the first release of VDDK required network access ESXi host (LAN or NBDSSL transport). With VDDK 1.1 programs can access virtual disks directly on a storage device, LAN-free. Direct SAN access increases I/O performance. To select the most efficient transport method, a set of APIs is available, including:

- `VixDiskLib_InitEx()` – Initializes the advanced transport library. You must specify the library location. Replaces `VixDiskLib_Init()` in your application.
- `VixDiskLib_ListTransportModes()` – Lists transport modes that the virtual disk library supports.
- `VixDiskLib_ConnectEx()` – Establishes a connection using the best transport mode available, or one you select, to access a given machine's virtual disk. Currently it does not check validity of transport type. Replaces `VixDiskLib_Connect()` in your application.

Initialize Virtual Disk API

`VixDiskLib_InitEx()` replaces `VixDiskLib_Init()` to initialize new releases of the library. Parameters are similar, except you should specify an actual `libDir`, and the `configFile` parameter is new. For multithreaded programming, you should write your own `logFunc`, because the default logging function is not thread-safe. `VixDiskLib` loads many libraries (DLLs or shared objects) at start time using

the Path or LD_LIBRARY_PATH environment. At run time, libDir specifies where to load advanced transport modes, whitelist, and blacklist. On Windows, *libDir could be C:\Program Files\VMware\VMware Virtual Disk Development Kit. On Linux, *libDir could be /usr/lib/vmware-vix-disklib.

```
VixError vixErr = VixDiskLib_InitEx(majorVersion, minorVersion, &logFunc, &warnFunc, &panicFunc,
    *libDir, *configFile);
```

Logged messages appear by default in a temporary folder or log directory, for VDDK and for many other VMware products. See [Location of Log Files](#).

The currently supported entries in the configFile are listed below. The correct way to specify a configuration is name=value. See below for a sample configuration file.

- tmpDirectory = "<TempDirectoryForLogging>"
- vixDiskLib.transport.LogLevel – Overrides default logging for vixDiskLib advanced transport functions, not including NFC (see nfc.LogLevel below). The default value is 3, indicating audit. Each level includes all of the messages generated by lower numbered levels. Here are the levels:
 - 0 = Panic (failure only)
 - 1 = Error
 - 2 = Warning
 - 3 = Audit
 - 4 = Info
 - 5 = Verbose
 - 6 = Trivia
- vixDiskLib.transport.san.blacklist – Specifies a device node path, or a comma separated list of device node paths, that VDDK uses as a list of LUNs on which not to attempt VMFS file system discovery. This has the effect of making fewer device nodes available to SAN transport, and avoids I/O on specific device node paths. The special string all indicates that VDDK should use only the device node paths specified by vixDiskLib.transport.san.whitelist.
- vixDiskLib.transport.san.whitelist – Specifies a device node path, or a comma separated list of device node paths, that VDDK uses as a list of LUNs on which to attempt VMFS file system discovery. This has the effect of making more device nodes available to SAN transport, encouraging I/O on specific device node paths. Backup applications may create a special device node and whitelist this device node for use in addition to those found by VDDK's device node scanner. Backup applications can also blacklist specific devices found by VDDK's device node scanner to prevent use by SAN transport. Combining whitelist and blacklist, applications can establish a preferred device policy for backup I/O.

- `vixDiskLib.disklib.EnableCache` – Caching by `vixDiskLib` is off (0) by default. Setting 1 turns it on. Caching increases performance when information is read repeatedly, or accessed randomly. In backup applications, information is usually accessed sequentially, and caching can actually reduce performance. Moreover with caching, backup applications risk getting stale information if a disk sector is rewritten (by another application) before the cache is refreshed.
- `vixDiskLib.linuxSSL.verifyCertificates` – Whether to check SSL certificates and thumbprints when connecting to a virtual machine. The only possible value is 1 for On, which is the default.

The following NFC related options override the default numbers provided to the various NFC functions. The NFC timeouts shown in the example (below `LogLevel`) correspond to default values on ESXi 5.x hosts.

- `vixDiskLib.nfc.AcceptTimeoutMs` – Overrides default value (3 minutes) for NFC accept operations.
- `vixDiskLib.nfc.RequestTimeoutMs` – Overrides default value (3 minutes) for NFC request operations.
- `vixDiskLib.nfc.ReadTimeoutMs` – Overrides default value (one minute) for NFC read operations. Similar to TCP keep-alive interval. See [NFC Session Limits and Timeouts](#).
- `vixDiskLib.nfc.WriteTimeoutMs` – Overrides default value (ten minutes) for NFC write operations.
- `vixDiskLib.nfcFssrvr.TimeoutMs` – Overrides the default value (default is 0, indefinite waiting) for NFC file system operations. If you specify a value, then a timeout occurs if the file system is idle for the indicated period of time. The hazard of using the default value is that in the rare case of a catastrophic communications failure, the file system will remain locked.
- `vixDiskLib.nfcFssrvrWrite.TimeoutMs` – Overrides the default value (default is no timeout) for NFC file system write operations. The timeout is specified in milliseconds. If you specify a value, it will time out when a write operation fails to complete in the specified time interval.
- `vixDiskLib.nfc.LogLevel` – Overrides the default logging level for NFC operations. The default value is 1, indicating error messages only. The meaning of values is listed here. Each level includes all of the messages generated by lower numbered levels. This is the final NFC setting.
 - 0 = Quiet (minimal logging)
 - 1 = Error
 - 2 = Warning
 - 3 = Info
 - 4 = Debug

Here is a sample `InitEx` configuration file:

```
# temporary directory for logs etc.
tmpDirectory="/usr/local/vendorapp/var/vmware/temp"
# log level 0 to 6 for quiet ranging to verbose
vixDiskLib.transport.LogLevel=2
# disable caching to disk
```

```
vixDiskLib.disklib.EnableCache=0
# whether to check SSL thumbprint on Linux - has no effect
vixDiskLib.linuxSSL.verifyCertificates=1
# network file copy options
vixDiskLib.nfc.AcceptTimeoutMs=180000
vixDiskLib.nfc.RequestTimeoutMs=180000
vixDiskLib.nfc.ReadTimeoutsMs=60000
vixDiskLib.nfc.WriteTimeoutsMs=600000
vixDiskLib.nfcFssrvr.TimeoutMs=0
vixDiskLib.nfcFssrvrWrite.TimeoutMs=0
# nfc.LogLevel (0 = Quiet, 1 = Error, 2 = Warning, 3 = Info, 4 = Debug)
vixDiskLib.nfc.LogLevel=2
```

Timeout values are stored in a 32-bit field, so the maximum timeout you may specify is 2G (2,147,483,648). Timeouts are specified in milliseconds and apply to each disk handle. NFC settings apply to NBD and NBDSSL, but not to SAN or HotAdd.

Phone Home Support

The Customer Experience Improvement Program (CEIP) is a way for VMware products to send telemetry data from on-premise and cloud-based products back to VMware.

Partners can ask VMware to share analytics so they can make data-driven decisions for their products. Developers can enable phone-home by adding the following line to the VDDK configuration file. Customers can disable phone-home by removing the line or setting the value to zero:

```
vixDiskLib.phoneHome.EnablePhoneHome = 1
```

VMware requests that developers add two subsequent lines for identification purposes:

```
vixDiskLib.phoneHome.ProductName = vendorName or ApplicationName
vixDiskLib.phoneHome.ProductVersion = versionNumber
```

Using the vSphere Web Client, customers can exit CEIP by clicking **Menu > Administration > Customer Experience Improvement Program > Leave**. This disables phone-home for all products. When customers leave CEIP, partner telemetry is disabled also, even if enabled in the VDDK configuration file.

Location of Log Files

On Linux, log messages appear under `/var/log` by default. On Windows, they appear in a temporary folder, whose location can change from time to time. Early Windows systems used `C:\Windows\Temp`. Windows XP and Server 2003 use `C:\Documents and Settings\<user>\Local Settings\Temp\vmware-<user>`. Vista, Windows 7, and Server 2008 use `C:\Users\<user>\AppData\Local\Temp\vmware-<user>`.

On all versions of Windows the user's TEMP environment setting overrides the default Temp folder location. Temporary is something of a misnomer because files are never deleted from the Temp folder, unless the user or an application deletes them. If the TEMP or Windows default Temp folder is not found, VDDK (and other VMware software) have a fallback to `<localAppDir>\Temp`.

Alternatively, your software can set a custom temporary directory, as shown in the sample InitEx file.

List Available Transport Methods

The `VixDiskLib_ListTransportModes()` function returns the currently supported transport methods as a colon-separated string value, currently "file:san:hotadd:nbdssl" where `nbdssl` indicates LAN transport. The default transport priority over the network is `san:hotadd:nbdssl` assuming all are available.

```
printf("Transport methods: %s\n", VixDiskLib_ListTransportModes());
```

Connect to VMware vSphere

`VixDiskLib_ConnectEx()` connects the library to managed disk on a remote ESXi host or through VMware vCenter Server. For hosted disk on the local system, it works the same as `VixDiskLib_Connect()`. `VixDiskLib_ConnectEx()` takes three additional parameters:

- Boolean indicating TRUE for read-only access, often faster, or FALSE for read/write access. If connecting read-only, later calls to `VixDiskLib_Open()` are always read-only regardless of the `openFlags` setting.
- Managed object reference (MoRef) of the snapshot to access using this connection. This is required for most transport methods (SAN, HotAdd, NBDSSL) and to access a powered-on virtual machine. You must also specify the associated `vmxSpec` property in `connectParams`. When connecting to an ESXi host, provide the ESXi MoRef. When connecting by vCenter Server, pass the vSphere MoRef, which differs.
- Preferred transport method, or NULL to accept the defaults. If you specify any advanced transport mode as the only method, and that method is not available, the `VixDiskLib_ConnectEx()` call does not fail, but the subsequent `VixDiskLib_Open()` call will fall back to NBDSSL mode.

```
VixDiskLibConnectParams cnxParams = {0};
if (appGlobals.isRemote) {
    cnxParams.vmName = vmxSpec;
    cnxParams.serverName = hostName;
    cnxParams.credType = VIXDISKLIB_CRED_UID;
    cnxParams.creds.uid.userName = userName;
    cnxParams.creds.uid.password = password;
    cnxParams.port = port;
}
VixError vixError = VixDiskLib_ConnectEx(&cnxParams, TRUE, "snapshot-47", NULL, &connection);
```

When a program calls `VixDiskLib_ConnectEx()` with `NULL` parameter to accept default transport mode, SAN is selected as the preferred mode, if SAN storage is available from the ESXi host. Then if the program opens a virtual disk on local storage, subsequent writes will fail. In this case, the program should explicitly pass `nbdssl` as the preferred transport mode.

The port is where vCenter Server listens for API queries. Specifying null allows the library to select the port, usually 443 (HTTPS). By default VADP uses the same port for virtual machine operations as other SOAP-based Web Services. By default VDDK uses port 902 (VIX automation) for NBDSSL data transport.

Connect to ESXi hosts

In the connection parameters `cnxParams`, the `vmxSpec` managed object reference would be different on an ESXi host than on the vCenter Server, as shown below. ESXi hosts offer no prepare-for and end access protection. Otherwise ESXi host connections are similar to vCenter Server connections.

```
vmxSpec = "moid=23498";
vmxSpec = "moid=898273";
```

Reuse a vCenter Server session

As of vSphere 6.5, you can recycle a vCenter Server session to avoid connection overflow. Set the credential type to `VIXDISKLIB_CRED_SESSIONID` and supply the value of `vmware_soap_session` from a still-live vCenter Server session.

```
if (appGlobals.isRemote) {
    cnxParams.vmName = vmxSpec;
    cnxParams.serverName = hostName;
    cnxParams.credType = VIXDISKLIB_CRED_SESSIONID;
    cnxParams.creds.sessionId.cookie = cookie;
    cnxParams.creds.sessionId.userName = userName;
    cnxParams.creds.sessionId.key = password;
    cnxParams.port = port;
}
```

Get Selected Transport Method

The `VixDiskLib_GetTransportMode()` function returns the transport method selected for `diskHandle`.

```
printf("Selected transport method: %s\n", VixDiskLib_GetTransportMode(diskHandle));
```

Prepare For Access and End Access

The `VixDiskLib_PrepareForAccess()` function notifies a vCenter-managed host that a virtual machine's disks are being opened, probably for backup, so the host should postpone virtual machine operations that might interfere with virtual disk access. Call this function before creating a snapshot on a virtual machine. Internally, this function disables the vSphere API method `RelocateVM_Task`.

```
vixError = VixDiskLib_PrepareForAccess(&cnxParams, "vmName");
```

The connection parameters must indicate one virtual machine only. When opening a managed disk, provide valid credentials for the vCenter Server that manages the ESXi host with the disk. The second parameter is currently just for identity tracking purposes, and is limited to 50 characters. It could be the virtual machine name or the name of your application. If you run `VixDiskLib_PrepareForAccess()` directly on an ESXi host, the system throws an error saying "VDDK: HostAgent is not a vCenter, cannot disable svmotion."

Every `VixDiskLib_PrepareForAccess()` call should have a matching `VixDiskLib_EndAccess()` call.

The `VixDiskLib_EndAccess()` function notifies the host that a virtual machine's disks have been closed, so operations that rely on the virtual disks to be closed, such as vMotion, can now be allowed. Call this function after closing all the virtual disks, and after deleting the virtual machine snapshot. Normally this function is called after previously calling `VixDiskLib_PrepareForAccess`, but you can call it to clean up after a crash. Internally, this function re-enables the vSphere API method `RelocateVM_Task`.

```
vixError = VixDiskLib_EndAccess(&cnxParams, "vmName");
```

Here is a code snippet showing use of `PrepareForAccess` in a backup program that waits up to 10 minutes for Storage vMotion to finish. Regular vMotion would finish much faster than that.

```
/* New sample code accounts for VMODL_TYPE_VIM_FAULT_METHOD_ALREADY_DISABLED_FAULT */
if (appGlobals.vmxSpec != NULL) {
    for (int i = 0; i < 10; i++) {
        vixError = VixDiskLib_PrepareForAccess(&cnxParams, "Sample");
        if (vixError == VIX_OK) {
            break;
        } else {
            Sleep(60000);
        }
    }
}
```

SAN Mode on Linux Uses Direct Mode

With SAN transport on Linux, read and write operations are performed in “direct” mode (O_DIRECT), meaning that no read or write buffering is done. Direct mode prevents other processes from accessing the latest data, and avoids loss of information if the process dies before committing its write buffers. In direct mode, the most time efficient performance can be achieved if applications follow these guidelines when performing reads and writes. These guidelines are applicable to Windows also.

- The buffer used for data transfer should be aligned on a page boundary.
- The transfer length should be an even multiple of the page size.

Clean Up After Disconnect

If virtual machine state was not cleaned up correctly after connection shut down, `VixDiskLib_Cleanup()` removes extra state for each virtual machine. Its three parameters specify connection, and pass back the number of virtual machines cleaned up, and the number remaining to be cleaned up.

```
int numCleanedUp, numRemaining;
VixError vixError = VixDiskLib_Cleanup(&cnxParams, &numCleanedUp, &numRemaining);
```

Ordering of Function Calls in Sequence

The code block below shows the suggested ordering of `VixDiskLib` function calls in sequence, including older function calls in combination with newer ones (Ex and Access).

For backup, the open, read, and close calls are made on virtual machine snapshots.

```
VixDiskLib_InitEx()
VixDiskLib_PrepareForAccess()
VixDiskLib_ConnectEx()
VixDiskLib_Open()
VixDiskLib_Read()
VixDiskLib_Close()
VixDiskLib_Disconnect()
VixDiskLib_EndAccess()
VixDiskLib_Cleanup()
VixDiskLib_Exit()
```

Updating Applications for Advanced Transport

To update your applications for advanced transport with managed disk, follow these steps:

Procedure

- 1 Find all instances of `VixDiskLib_Connect()` and change them to `VixDiskLib_ConnectEx()`.
The `vixDiskLib` sample program was extended to use `VixDiskLib_ConnectEx()` with the `-mod` option.
- 2 Likewise, change `VixDiskLib_Init()` to `VixDiskLib_InitEx()` and be sure to call it only once.
- 3 Disable virtual machine relocation with the `VixDiskLib_PrepareForAccess()` call.
- 4 Add parameters in the middle:
 - TRUE for high performance read-only access, FALSE for read/write access.
 - Snapshot `moRef`, if applicable.
 - NULL to accept transport method defaults (recommended).
- 5 Re-enable virtual machine relocation with the `VixDiskLib_EndAccess()` call.
- 6 Find `VixDiskLib_Disconnect()` near the end of program, and for safety add a `VixDiskLib_Cleanup()` call immediately afterwards.
- 7 Compile with the new flexible-transport-enabled version of `VixDiskLib`.

The advanced transport functions are useful for backing up or restoring data on virtual disks managed by VMware vSphere. Backup is based on the snapshot mechanism, which provides a data view at a certain point in time, and allows access to quiescent data on the parent disk while the child disk continues changing.

Algorithm for vSphere Backup

A typical backup application follows this algorithm:

- Preferably through vCenter Server, contact the ESXi host and discover the target virtual machine.
- Ask the ESXi host to take a snapshot of the target virtual machine.
- Using the vSphere API (`PropertyCollector`), capture configuration (`VirtualMachineConfigInfo`) and changed block information (with `queryChangedDiskAreas`). Save these for later.
- Using advanced transport functions and `VixDiskLib`, access the snapshot and save the data in it. If Changed Block Tracking is enabled, the snapshot contains only incremental backup data.
- Ask the ESXi host to delete the backup snapshot.

A typical back-in-time disaster recovery or file-based restore follows this algorithm:

- Preferably through VMware vCenter, contact the ESXi host containing the target virtual machine.
- Ask the ESXi host to halt and power off the target virtual machine.
- Using advanced transport functions, restore a snapshot from saved backup data.
- For disaster recovery to a previous point in time, have the virtual machine revert to the restored snapshot. For file-based restore, mount the snapshot and restore requested files.

[Chapter 7 Backing Up Virtual Disks in vSphere](#) presents these algorithms in more detail and includes code samples. For best practices in backup and restore, see [Tips and Best Practices](#).

Backup and Recovery Example

The VMware vSphere API method `queryChangedDiskArea` returns a list of disk sectors that changed between an existing snapshot, and some previous time identified by a change ID.

The `queryChangedDiskAreas` method takes four arguments, including a snapshot reference and a change ID. It returns a list of disk sectors that changed between the time indicated by the change ID and the time of the snapshot. This is useful for incremental backup. Before a full backup, you can call `VixDiskLib_QueryAllocatedBlocks` to get a list of in-use disk sectors so your backup can skip unallocated sectors.

Suppose that you create an initial backup at time $T1$. Later at time $T2$ you take an incremental backup, and another incremental backup at time $T3$. (You could use differential backups instead of incremental backups, which would trade off greater backup time and bandwidth for shorter restore time.)

For the full backup at time $T1$:

- 1 Keep a record of the virtual machine configuration, `VirtualMachineConfigInfo`.
- 2 Create a snapshot of the virtual machine, naming it **snapshot_T1**.
- 3 Obtain the change ID for each virtual disk in the snapshot, **changeld_T1** (per VMDK).
- 4 Back up the sectors returned by `VixDiskLib_QueryAllocatedBlocks`, avoiding unallocated disk.
- 5 Delete **snapshot_T1**, keeping a record of **changeld_T1** along with lots of backed-up data.

For the incremental backup at time $T2$:

- 1 Create a snapshot of the virtual machine, naming it **snapshot_T2**.
- 2 Obtain the change ID for each virtual disk in the snapshot, **changeld_T2** (per VMDK).
- 3 Back up the sectors returned by `queryChangedDiskAreas(snapshot_T2,... changeId_T1)`.
- 4 Delete **snapshot_T2**, keeping a record of **changeld_T2** along with backed-up data.

For the incremental backup at time $T3$:

- 1 Create a snapshot of the virtual machine, naming it **snapshot_T3**.

At time $T3$ you can no longer obtain a list of changes between $T1$ and $T2$.

- 2 Obtain the change ID for each virtual disk in the snapshot, **changeld_T3** (per VMDK).
- 3 Back up the sectors returned by `queryChangedDiskAreas(snapshot_T3,... changeId_T2)`.
A differential backup could be done with `queryChangedDiskAreas(snapshot_T3,... changeId_T1)`.
- 4 Delete **snapshot_T3**, keeping a record of **changeld_T3** along with backed-up data.

For a disaster recovery at time T4:

- 1 Create a new virtual machine with no guest operating system installed, using configuration parameters you previously saved from `VirtualMachineConfigInfo`. You do not need to format the virtual disks, because restored data includes formatting information.
- 2 Restore data from the backup at time T3. Keep track of which disk sectors you restore.
- 3 Restore data from the incremental backup at time T2, skipping any sectors already recovered. With differential backup, you can skip copying the T2 backup.
- 4 Restore data from the full backup at time T1, skipping any sectors already recovered. The reason for working backwards is to get the newest data while avoiding unnecessary data copying.
- 5 Power on the recovered virtual machine.

When programs open remote disk with SAN transport mode, they can write to the base disk, but they cannot write to a snapshot (redo log). Opening and writing snapshots is supported only for hosted disk.

Multithreading Considerations

In multithreaded programs, disk requests should be serialized by the client program. Disk handles are not bound to a thread and may be used across threads. You can open a disk in one thread and use its handle in another thread, provided you serialize disk access. Alternatively you can use a designated open-close thread, as shown in the workaround below.

Multiple Threads and VixDiskLib

VDDK supports concurrent I/O to multiple virtual disks, with certain limitations:

- `VixDiskLib_InitEx()` or `VixDiskLib_Init()` should be called once per process, from the main thread.
- In the `VixDiskLib_InitEx()` or `VixDiskLib_Init()` function call, do not specify logging callbacks as `NULL`. This causes `VixDiskLib` to provide its default logging functions, which are not thread safe. If you are using VDDK in a multithreaded environment, you must provide your own thread-safe log functions.
- When you call `VixDiskLib_Open()` and `VixDiskLib_Close()`, VDDK initializes and uninitialized a number of libraries, some of which do not work if called from multiple threads. For example, this fails:

```
Thread 1: VixDiskLib_Open ..... VixDiskLib_Close
Thread 2: ..... VixDiskLib_Open ..... VixDiskLib_Close
```

The workaround is to use one designated thread to do all opens and closes, and to have other worker threads doing reads and writes. This diagram shows concurrent reads on two separate disk handles. Concurrent reads on the same disk handles are not allowed.

```

Open/Close Thread:
VixDiskLib_Open ..... VixDiskLib_Open ..... VixDiskLib_Close ..... VixDiskLib_Close .....
(handle1)                (handle2)                (handle1)                (handle2)
I/O Thread 1:
(owns handle1)  VixDiskLib_Read ... VixDiskLib_Read ...
I/O Thread 2:
(owns handle2)                VixDiskLib_Read ... VixDiskLib_Read ...

```

Capabilities of Library Calls

This section describes limitations, if any.

Support for Managed Disk

Some operations are not supported:

- For `VixDiskLib_Connect()` to open a managed disk connection, you must provide valid vSphere access credentials. On ESXi hosts, `VixDiskLib_Open()` cannot open a single link in a disk chain.
- For `VixDiskLib_Create()` to create a managed disk on an ESXi host, first create a hosted type disk, then use `VixDiskLib_Clone()` to convert the hosted virtual disk to managed virtual disk.
- `VixDiskLib_Defragment()` can defragment hosted disks only.
- `VixDiskLib_Grow()` can grow hosted disks only.
- `VixDiskLib_Unlink()` can delete hosted disks only.
- Until ESXi 5.1, the HotAdd transport was available only with vSphere Enterprise Edition and higher.

Support for Hosted Disk

Most everything (except advanced transport) is supported, except:

- The `VixDiskLib_ConnectEx()` extended connect function.
- SAN and HotAdd advanced transports.
- `VixDiskLib_PrepareForAccess()` and `VixDiskLib_EndAccess()` to delay Storage VMotion.

Virtual Disk API Sample Code

This chapter discusses the VDDK sample program, in the following sections:

This chapter includes the following topics:

- [Compiling the Sample Program](#)
- [Usage Message](#)
- [Walk-Through of Sample Program](#)

Compiling the Sample Program

The sample program is written in C++, although the Virtual Disk API also supports C. For compilation to succeed, the correct DLLs or shared objects must be loaded. You can ensure the success of dynamic loading in a variety of ways.

- Set the path inside the VDDK program.
- Set the path for the shell being used in Linux or in Visual Studio for Windows.

For a default installation, the Linux path is `/usr/share/doc/vmware-vix-disklib/sample`.

- In Windows, set the Path element in the System Variables.

To do this in Windows XP, right-click **Computer > Properties > Advanced > Environment Variables**, select Path in the System Variables lower list, click Edit, and add the path of the VDDK bin directory.

In Windows 7, right-click **Computer > Properties > Advanced System Settings > Environment Variables**, select Path in the **System Variables** list, click Edit, and add the path of the VDDK bin directory.

`C:\Program Files\VMware\VMware Virtual Disk Development Kit\doc\sample\` is the default path.

Note that VDDK loads DLLs by relative path rather than absolute path, so conflicting versions of the DLLs could cause problems.

Visual C++ on Windows

To compile the program, find the sample source `vixDiskLibSample.cpp` at this location:

C:\Program Files\VMware\VMware Virtual Disk Development Kit\doc\sample\

For VDDK 5.5 and later, make sure that you have the 64-bit debugging tools installed along with Visual Studio. Double-click the vcproj file, possibly convert format to a newer version, and choose Build > Build Solution.

To execute the compiled program, choose Debug > Start Without Debugging, or type this in a command prompt after changing to the doc\sample location given above:

```
Debug\vixdisklibsampl.exe
```

SLN and VCPROJ Files

The Visual Studio solution file vixDiskLibSample.sln and project file vixDiskLibSample.vcproj are included in the sample directory.

C++ on Linux Systems

Find the sample source in this directory:

```
/usr/share/doc/vmware-vix-disklib/samples/diskLib
```

You can copy vixDiskLibSample.cpp and its Makefile to a directory where you have write permission, or switch user to root. On some Linux systems you need to add #include statements for <stdio.h> and <string.h> after the #else clause on line 15. Type the make command to compile. Run the application:

```
make
```

```
./vix-disklib-sample
```

Note If this fails, edit /etc/ld.so.conf and run ldconfig as root or change your LD_LIBRARY_PATH environment to include the library installation path, /usr/lib/vmware-vix-disklib/lib64.

Makefile

The Makefile fetches any packages that are required for compilation but are not installed.

Library Files Required

The virtual disk library comes with dynamic libraries, or shared objects on Linux, to simplify the delivery of third-party and open source components.

Windows requires the lib/vixDiskLib.lib file for linking, and the bin/*.dll files at runtime.

Linux uses .so files for both linking and running.

Usage Message

Running the sample application without arguments produces the following usage message:

```
Usage: vixdisklibsampl command [options] diskPath
commands:
  -create : creates a sparse virtual disk with capacity specified by -cap
  -redo parentPath : creates a redo log 'diskPath' for base disk 'parentPath'
  -info : displays information for specified virtual disk
  -dump : dumps the contents of specified range of sectors in hexadecimal
  -fill : fills specified range of sectors with byte value specified by -val
  -wmeta key value : writes (key,value) entry into disk's metadata table
  -rmeta key : displays the value of the specified metada entry
  -meta : dumps all entries of the disk's metadata
  -clone sourcePath : clone source vmdk possibly to a remote site
  -readbench blocksize: do read benchmark on a disk using the specified I/O block size in sectors
  -writebench blocksize: do write benchmark on disk using the specified I/O block size in sectors
options:
  -adapter [ide|scsi] : bus adapter type for 'create' option (default='scsi')
  -start n : start sector for 'dump/fill' options (default=0)
  -count n : number of sectors for 'dump/fill' options (default=1)
  -val byte : byte value to fill with for 'write' option (default=255)
  -cap megabytes : capacity in MB for -create option (default=100)
  -single : open file as single disk link (default=open entire chain)
  -multithread n: start n threads and copy the file to n new files
  -host hostname : hostname / IP addresss (ESXi or vCenter)
  -user userid : user name on host (default = root)
  -password password : password on host
  -port port : port to use to connect to host (default = 443)
  -vm vmPath=/path/to/vm : inventory path to vm that owns the virtual disk
  -libdir dir : Directory containing vixDiskLibPlugin library
  -initex configfile : Use VixDiskLib_InitEx
  -ssmoref moref : Managed object reference of VM snapshot
  -mode mode : Mode string to pass into VixDiskLib_ConnectEx
  -thumb string : Provides a SSL thumbprint string for validation
```

The `-thumb` option is a new security-related feature in the VDDK 5.1 release. See [SSL Certificate Thumbprint](#).

The sample program's `-single` option, which opens a single link instead of the entire disk chain, is supported for (local) hosted disk, but not for (remote) managed disk.

To connect to an ESXi host with the sample program, you must specify the options `-host`, `-user`, `-password`, and provide a `diskPath` on the ESXi host's datastore. For example:

```
vix-diskLib-sample -info -host esx5 -user root -password secret "[datastore1] <VM>/<VM>.vmdk"
```

To connect to vCenter Server, you must also specify the options `-libdir` and `-vm`. Programs need `libdir` so the `DiskLibPlugin` can connect with vCenter Server, which must locate the VM. For example:

```
vix-disklib-sample -info -host vc5 -user Administrator -password secret
                    -libdir <pluginDir> -vm vmPath=<path/to/VM> "[<partition>] <VM>/<VM>.vmdk"
```

The `vmPath` is formulated in vSphere Client by starting at vCenter and inserting `/vm/` before the VM name. The `diskPath` is ascertained by clicking **Edit Settings > Hard Disk** and copying the **Disk File** name.

```
vix-disklib-sample -info -host vc5 -user Administrator -password secret
                    -libdir /usr/lib/vmware-vix-disklib/lib64 -vm vmPath=Datacenter/vm/RHEL5
                    "[datastore1] RHEL5/RHEL5.vmdk"
```

To connect using an advanced transport, for example to virtual machine disk on SAN storage, you must also specify the options `-mode` and `-ssmoref`. The transport mode and managed object reference (of a snapshot) are required for `VixDiskLib_ConnectEx()`. To find the `ssmoref`, log in to the managed object browser for the vCenter Server, and click **content > rootFolder > Datacenter > datastore > vm > snapshot**. A snapshot must exist, because it is a bad idea to open the base disk of a powered-on VM.

```
vix-disklib-sample -info -host vc5 -user Administrator -password secret -mode san
                    -libdir /usr/lib/vmware-vix-disklib/lib64 -vm vmPath=Datacenter/vm/RHEL5
                    -ssmoref snapshot-72 "[datastore1] RHEL5/RHEL5.vmdk"
```

On Windows, the VDDK package installs `diskLibPlugin.dll` in the `\bin` folder, not the `\lib` folder, so change `<pluginDir>` accordingly.

Walk-Through of Sample Program

The sample program is the same for Windows as for Linux, with `#ifdef` blocks for Win32.

Include Files

Windows dynamic link library (DLL) declarations are in `process.h`, while Linux shared object (`.so`) declarations are in `dLfcn.h`. Windows offers the `tchar.h` extension for Unicode generic text mappings, not readily available in Linux.

Definitions and Structures

The sample program uses twelve bitwise shift operations (`1 << 11`) to track its available commands and the multithread option. The Virtual Disk API has about 30 library functions, some for initialization and cleanup. The following library functions are not demonstrated in the sample program:

- `VixDiskLib_Rename()`
- `VixDiskLib_Defragment()`
- `VixDiskLib_Grow()`

- `VixDiskLib_Shrink()`
- `VixDiskLib_Unlink()`
- `VixDiskLib_Attach()`

The sample program transmits state in the `appGlobals` structure.

Dynamic Loading

The `#ifdef DYNAMIC_LOADING` block is long, starting on line 97 and ending at line 339. This block contains function definitions for dynamic loading. It also contains the `LoadOneFunc()` procedure to obtain any requested function from the dynamic library and the `DynLoadDiskLib()` procedure to bind it. This demonstration feature could also be called “runtime loading” to distinguish it from dynamic linking.

To try the program with runtime loading enabled on Linux, add `-DDYNAMIC_LOADING` after `g++` in the Makefile and recompile. On Windows, define `DYNAMIC_LOADING` in the project.

Wrapper Classes

Below the dynamic loading block are two wrapper classes, one for error codes and descriptive text, and the other for the connection handle to disk.

The error wrapper appears in `catch` and `throw` statements to simplify error handling across functions.

Wrapper class `VixDisk` is a clean way to open and close connections to disk. The only time that library functions `VixDiskLib_Open()` and `VixDiskLib_Close()` appear elsewhere, aside from dynamic loading, is in the `CopyThread()` function near the end of the sample program.

Command Functions

The print-usage message appears next, with output partially shown in [Usage Message](#).

Next comes the `main()` function, which sets defaults and parses command-line arguments to determine the operation and possibly set options to change defaults. Dynamic loading occurs, if defined. Notice the all-zero initialization of the `VixDiskLibConnectParams` declared structure:

```
VixDiskLibConnectParams cnxParams = {0};
```

For connections to an ESXi host, credentials including user name and password must be correctly supplied in the `-user` and `-password` command-line arguments. Both the `-host` name of the ESXi host and its `-vm` inventory path (`vmxSpec`) must be supplied. When set, these values populate the `cnxParams` structure. Initialize all parameters, especially `vmxSpec`, or else the connection might behave unexpectedly.

A call to `VixDiskLib_Init()` initializes the library. In a production application, you can supply appropriate `log`, `warn`, and `panic` functions as parameters, in place of `NULL`.

A call to `VixDiskLib_Connect()` creates a connection to disk. If host `cnxParams.serverName` is null, as it is without the `-host` argument, a connection is made to hosted disk on the local host. Otherwise a connection is made to managed disk on the remote host. With `-ssmoref` argument, advanced transport is used.

Next, an appropriate function is called for the requested operation, followed by error information if applicable. Finally, the `main()` function closes the library connection to disk and exits.

DoInfo()

This procedure calls `VixDiskLib_GetInfo()` for information about the virtual disk, displays results, and calls `VixDiskLib_FreeInfo()` to reclaim memory. The parameter `disk.Handle()` comes from the `VixDisk` wrapper class discussed in [Wrapper Classes](#).

In this example, the sample program connects to an ESXi host named `esx5` and displays virtual disk information for a Red Hat Enterprise Linux client. For an ESXi host, path to disk is often something like `[datastore1]` followed by the virtual machine name and the VMDK filename.

```
vix-diskLib-sample -info -host esx5 -user root -password secret "[datastore1] RHEL6/RHEL6.vmdk"
```

```
vix-diskLib-sample -info -host esx5 -user root -password secret "[datastore1] RHEL6/RHEL6.vmdk"
Disk "[datastore1] RHEL6/RHEL6.vmdk" is open using transport mode "nbdssl".
capacity           = 4194304 sectors
number of links    = 1
adapter type       = LsiLogic SCSI
BIOS geometry     = 0/0/0
physical geometry = 261/255/63
Transport modes supported by vixDiskLib: file:nbdssl
```

If you multiply physical geometry numbers (261 cylinders * 255 heads per cylinder * 63 sectors per head) the result is a capacity of 4192965 sectors, although the first line says 4194304. A small discrepancy is possible due to rounding. In general, you get at least the capacity that you requested. The number of links specifies the separation of a child from its original parent in the disk chain (redo logs), starting at one. The parent has one link, its child has two links, the grandchild has three links, and so forth.

DoCreate()

This procedure calls `VixDiskLib_Create()` to allocate virtual disk. Adapter type is SCSI unless specified as IDE on the command line. Size is 100MB, unless set by `-cap` on the command line. Because the sector size is 512 bytes, the code multiplies `appGlobals.mbsize` by 2048 instead of 1024. Type is always monolithic sparse and Workstation 5. In a production application, `progressFunc` and `callback` data can be defined rather than NULL. Type these commands to create a sample VMDK file (the first line is for Linux only):

```
export LD_LIBRARY_PATH=/usr/lib/vmware-vix-disklib/lib64
```

```
vix-disklib-sample -create sample.vmdk
```

As a VMDK file, monolithic sparse (growable in a single file) virtual disk is initially 65536 bytes (2^{16}) in size, including overhead. The first time you write to this type of virtual disk, as with `DoFill()` below, the VMDK expands to 131075 bytes (2^{17}), where it remains until more space is needed. You can verify file contents with the `-dump` option.

DoRedo()

This procedure calls `VixDiskLib_CreateChild()` to establish a redo log. A child disk records disk sectors that changed since the parent disk or previous child. Children can be chained as a set of redo logs.

The sample program does not demonstrate use of `VixDiskLib_Attach()`, which you can use to access a link in the disk chain. `VixDiskLib_CreateChild()` establishes a redo log, with the child replacing the parent for read/write access. Given a pre-existing disk chain, `VixDiskLib_Attach()` creates a related child, or a cousin you might say, that is linked into some generation of the disk chain.

For a diagram of the attach operation, see [Attach Child to Parent Disk](#).

Write by DoFill()

This procedure calls `VixDiskLib_Write()` to fill a disk sector with ones (byte value FF) unless otherwise specified by `-val` on the command line. The default is to fill only the first sector, but this can be changed with options `-start` and `-count` on the command line.

DoReadMetadata()

This procedure calls `VixDiskLib_ReadMetadata()` to serve the `-rmeta` command-line option. For example, type this command to obtain the universally unique identifier:

```
vix-disklib-sample -rmeta uuid sample.vmdk
```

DoWriteMetadata()

This procedure calls `VixDiskLib_WriteMetadata()` to serve the `-wmeta` command-line option. For example, you can change the tools version from 1 to 2 as follows:

```
vix-disklib-sample -wmeta toolsVersion 2 sample.vmdk
```

DoDumpMetadata()

This procedure calls `VixDiskLib_GetMetadataKeys()` then `VixDiskLib_ReadMetadata()` to serve the `-meta` command-line option. Two read-metadata calls are needed for each key: one to determine length of the value string and another to fill in the value. See [Get Metadata Table from Disk](#).

In the following example, the sample program connects to an ESXi host named `esx3` and displays the metadata of the Red Hat Enterprise Linux client's virtual disk. For an ESXi host, path to disk might be `[storage1]` followed by the virtual machine name and the VMDK filename.

```
vix-diskLib-sample -meta -host esx3 -user admin -password secret "[storage1]RHEL5/RHEL5.vmdk"
geometry.sectors = 63
geometry.heads = 255
geometry.cylinders = 522
adapterType = buslogic
toolsVersion = 1
virtualHWVersion = 7
```

Tools version and virtual hardware version appear in the metadata, but not in the disk information retrieved by `DoInfo()`. Geometry information and adapter type are repeated, but in a different format. Other metadata items not listed above might exist.

DoDump()

This procedure calls `VixDiskLib_Read()` to retrieve sectors and displays sector contents on the output in hexadecimal. The default is to dump only the first sector numbered zero, but you can change this with the `-start` and `-count` options. Here is a sequence of commands to demonstrate:

```
vix-disklib-sample -create sample.vmdk
vix-disklib-sample -fill -val 1 sample.vmdk
vix-disklib-sample -fill -val 2 -start 1 -count 1 sample.vmdk
vix-disklib-sample -dump -start 0 -count 2 sample.vmdk
od -c sample.vmdk
```

On Linux (or Cygwin) you can run the `od` command to show overhead and metadata at the beginning of file, and the repeated ones and twos in the first two sectors. The `-dump` option of the sample program shows only data, not overhead.

DoTestMultiThread()

This procedure employs the Windows thread library to make multiple copies of a virtual disk file. Specify the number of copies with the `-multithread` command-line option. For each copy, the sample program calls the `CopyThread()` procedure, which in turn calls a sequence of six Virtual Disk API routines.

On Linux the multithread option is unimplemented.

DoClone()

This procedure calls `VixDiskLib_Clone()` to make a copy of the data on virtual disk. A callback function, supplied as the sixth parameter, displays the percent of cloning completed. For local hosted disk, the adapter type is SCSI unless specified as IDE on the command line, size is 200MB, unless set by `-cap` option, and type is monolithic sparse, for Workstation. For an ESXi host, adapter type is taken from managed disk itself, using the connection parameters established by `VixDiskLib_Connect()`.

If `createParams.diskType` is `VIXDISKLIB_DISK_VMFS_THIN`, clone converts the destination VMDK to thin. This is an exception to ignoring `createParams` for the remote case.

The final parameter TRUE means to overwrite if the destination VMDK exists.

The clone option is a good backup method. Sometimes a cloned virtual disk is smaller, because it can be organized more efficiently. Moreover, a fully allocated flat file can be converted to sparse or thin representation.

SSL Certificate Thumbprint

The sample program in the VDDK 5.1 release added the `-thumb` option to allow an SSL certificate thumbprint to be provided and used. The thumbprint is used for authentication through vCenter Server.

Practical Programming Tasks

This chapter presents some practical programming challenges not covered in the sample program, including:

This chapter includes the following topics:

- [Scan VMDK for Virus Signatures](#)
- [Creating Virtual Disks](#)
- [VMDK File Versions](#)
- [Working with Virtual Disk Data](#)
- [Managing Child Disks](#)
- [RDM Disks and Virtual BIOS](#)
- [Interfacing With VMware vSphere](#)

Scan VMDK for Virus Signatures

One of the [Use Cases for the Virtual Disk Library](#) is to scan a VMDK for virus signatures. Using our sample program framework, this example function implements the `-virus` command-line option, using hypothetical library routine `SecureVirusScan()`, supplied by an antivirus software vendor. The library routine scans a buffer against the vendor's latest pattern library, returning `TRUE` if it identifies a virus.

```
extern int SecureVirusScan(const uint8 *buf, size_t n);
/*
 * DoVirusScan - Scan the content of a virtual disk for virus signatures.
 */
static void DoVirusScan(void)
{
    VixDisk disk(appGlobals.connection, appGlobals.diskPath, appGlobals.openFlags);
    VixDiskLibDiskInfo info;
    uint8 buf[VIXDISKLIB_SECTOR_SIZE];
    VixDiskLibSectorType sector;

    VixError vixError = VixDiskLib_GetInfo(disk.Handle(), &info);
    CHECK_AND_THROW(vixError);
    cout << "capacity = " << info.capacity << " sectors" << endl;
    // read all sectors even if not yet populated
    for (sector = 0; sector < info.capacity; sector++) {
        vixError = VixDiskLib_Read(disk.Handle(), sector, 1, buf);
```

```

CHECK_AND_THROW(vixError);
if (SecureVirusScan(buf, sizeof buf) {
    printf("Virus detected in sector %d\n", sector);
}
}
cout << info.capacity << " sectors scanned" << endl;
}

```

This function calls `VixDiskLib_GetInfo()` to determine the number of sectors allocated in the virtual disk. The number of sectors is available in the `VixDiskLibDiskInfo` structure, but normally not in the metadata. With SPARSE type layout, data can occur in any sector, so this function reads all sectors, whether filled or not. `VixDiskLib_Read()` continues without error when it encounters an empty sector full of zeroes.

The following difference list shows the remaining code changes necessary for adding the `-virus` option to the `vixDiskLibSample.cpp` sample program:

```

43a44
> #define COMMAND_VIRUS_SCAN      (1 << 10)
72a74
> static void DoVirusScan(void);
425a429
>     printf(" -virus: scan source vmdk for virus signature \n");
519a524,525
>     } else if (appGlobals.command & COMMAND_VIRUS_SCAN) {
>         DoVirusScan();
564a571,572
>     } else if (!strcmp(argv[i], "-virus")) {
>         appGlobals.command |= COMMAND_VIRUS_SCAN;

```

Creating Virtual Disks

This section discusses the types of local VMDK files and how to create virtual disk for a remote ESXi host.

Create Local Disk

The sample program presented in [Chapter 5 Virtual Disk API Sample Code](#) creates virtual disk of type `MONOLITHIC_SPARSE`, in other words one big file, not pre-allocated. This is the default because modern file systems, in particular NTFS, support files larger than 2GB, and can hold more than 2GB of total data. This is not true of legacy file systems, such as FAT16 on MS-DOS and early Windows, or the ISO9660 file system for writing files on CD, or NFS version 2, or Linux kernel 2.4. All are limited to 2GB per volume. FAT and FAT32 were extended to 4GB in NT 3.51.

However, a SPLIT virtual disk might be safer than the MONOLITHIC variety, because if something goes wrong with the underlying host file system, some data might be recoverable from uncorrupted 2GB extents. VMware products do their best to repair a damaged VMDK, but having a split VMDK increases the chance of salvaging files during repair. On the downside, SPLIT virtual disk involves higher overhead (more file descriptors) and increases administrative complexity.

When required for a FAT16 or early Linux file system, you can create SPLIT_SPARSE virtual disk. The change is simple: the line highlighted in boldface. The sample program could be extended to have an option for this.

```
static void DoCreate(void)
{
    VixDiskLibAdapterType adapter = strcmp(appGlobals.adapterType, "scsi") == 0 ?
        VIXDISKLIB_ADAPTER_SCSI_BUSLOGIC : VIXDISKLIB_ADAPTER_IDE;
    VixDiskLibCreateParams createParams;
    VixError vixError;
    createParams.adapterType = adapter;
    createParams.capacity = appGlobals.mbSize * 2048;
    createParams.diskType = VIXDISKLIB_DISK_SPLIT_SPARSE;
    vixError = VixDiskLib_Create(appGlobals.connection, appGlobals.diskPath, &createParams, NULL, NULL);
    CHECK_AND_THROW(vixError);
}
```

Note You can split VMDK files into smaller than 2GB extents, but created filenames still follow the patterns shown in [Table 3-1](#).

This one-line change to DoCreate() causes creation of 200MB split VMDK files (200MB being the capacity set on the previous line) unless the `-cap` command-line argument specifies otherwise.

Create Remote Disk

As stated in [Support for Managed Disk](#), VixDiskLib_Create() does not support managed disk. To create a managed disk on the remote ESXi host, first create a hosted disk on the local Workstation, then convert the hosted disk into managed disk with VixDiskLib_Clone() over the network.

To create remote managed disk using the sample program, type the following commands:

```
./vix-disklib-sample -create -cap 1000000 virtdisk.vmdk
./vix-disklib-sample -clone virtdisk.vmdk -host esx3i -user root -password secret
vmfsdisk.vmdk
```

You could write a virtual-machine provisioning application to perform the following steps:

Procedure

- 1 Create a hosted disk VMDK with 2GB capacity, using VixDiskLib_Create().
- 2 Write image of the guest OS and application software into the VMDK, using VixDiskLib_Write().
- 3 Clone the hosted disk VMDK onto the VMFS file system of the ESXi host.

```
vixError = VixDiskLib_Clone(appGlobals.connection, appGlobals.diskPath,
    srcConnection, appGlobals.srcPath,
    &createParams, CloneProgressFunc, NULL, TRUE);
```

In this call, `appGlobals.connection` and `appGlobals.diskPath` represent the remote VMDK on the ESXi host, while `srcConnection` and `appGlobals.srcPath` represent the local hosted VMDK.

- 4 Power on the new guest OS to get a new virtual machine.

On Workstation, the `VixVMPowerOn()` function in the VIX API does this. For ESXi hosts, you must use the `PowerOnVM_Task` method. An easy way to use this method is in the VMware vSphere Perl Toolkit, which has the `PowerOnVM_Task()` call (non-blocking), and the `PowerOnVM()` call (synchronous).

- 5 Provision and deploy the new virtual machine on the ESXi host.

Special Consideration for ESXi Hosts

No matter what virtual file type you create in Step 1, it becomes type `VIXDISKLIB_DISK_VMFS_FLAT` in Step 3.

VMDK File Versions

Virtual disk programs must be able to cope with VMDK files up to version three (3).

Version 1 was the initial version of VMDK. All released builds of `vixDiskLib` can read and write this version.

Version 2 added disk encryption for hosted products (Workstation and Fusion), although encrypted disks were never implemented on ESXi. Version 2 VMDK files can be transferred to and appear on ESXi, where they are treated like version 1 VMDK files.

Version 3 added support for persistent changed block tracking (CBT), and is set when CBT is enabled for a virtual disk. CBT is supported on VMFS datastores. This version 3 first appeared in ESXi 4.0 and continues unchanged in recent vSphere releases. When CBT is enabled, the version number is incremented, and decremented when CBT is disabled.

If you look at the `.vmdk` descriptor file for a version 3 virtual disk, you can see a pointer to its `*-ctk.vmdk` ancillary file. For example:

```
version=3
...
# Change Tracking File
changeTrackPath="Windows-2008R2x64-2-ctk.vmdk"
```

The `changeTrackPath` setting references a file that describes changed areas on the virtual disk.

If you want to back up the changed area information, then your software should copy the `*-ctk.vmdk` file and preserve the “Change Tracking File” line in the `.vmdk` descriptor file. If you do not want to back up the changed area information, then you can discard the ancillary file, remove the “Change Tracking File” line, read the VMDK file data as if it were version 1, and roll back the version number on restore.

Working with Virtual Disk Data

The virtual disk library reads and writes sectors of data. It has no interface for character or byte-oriented I/O.

Reading and Writing Local Disk

Demonstrating random I/O, this function reads a sector at a time backwards through a VMDK. If it sees the string “VmWare” it substitutes the string “VMware” in its place and writes the sector back to VMDK.

```
#include <string>
static void DoEdit(void)/
{
    VixDisk disk(appGlobals.connection, appGlobals.diskPath, appGlobals.openFlags);
    uint8 buf[VIXDISKLIB_SECTOR_SIZE];
    VixDiskLibSectorType i;
    string str;
    for (i = appGlobals.numSectors; i >= 0; i--) {
        VixError vixError;
        vixError = VixDiskLib_Read(disk.Handle(), appGlobals.startSector + i, 1, buf);
        CHECK_AND_THROW(vixError);
        str = buf;
        if (pos = str.find("VmWare", 0)) {
            str.replace(pos, 5, "VMware");
            buf = str;
            vixError = VixDiskLib_Write(disk.Handle(), appGlobals.startSector + i, 1, buf);
            CHECK_AND_THROW(vixError);
        }
    }
}
```

Reading and Writing Remote Disk

The DoEdit() function is similar for remote managed virtual disk on ESXi hosts, but beforehand you must call VixDiskLib_Connect() with authentication credentials instead of passing NULL parameters.

```
if (appGlobals.isRemote) {
    cnxParams.vmxSpec = NULL;
    cnxParams.serverName = appGlobals.host;
    cnxParams.credType = VIXDISKLIB_CRED_UID;
    cnxParams.creds.uid.userName = appGlobals.userName;
    cnxParams.creds.uid.password = appGlobals.password;
    cnxParams.port = appGlobals.port;
}
VixError vixError = VixDiskLib_Init(1, 0, NULL, NULL, NULL, NULL);
CHECK_AND_THROW(vixError);
vixError = VixDiskLib_Connect(&cnxParams, &appGlobals.connection);
```

Deleting a Disk (Unlink)

The function to delete virtual disk files is VixDiskLib_Unlink(). It takes two arguments: a connection and a VMDK filename.

```
vixError = VixDiskLib_Unlink(appGlobals.connection, appGlobals.diskPath);
```

Effects of Deleting a Virtual Disk

When you delete a VMDK, you lose all the information it contained. In most cases, the host operating system prevents you from doing this when a virtual machine is running. However, if you delete a VMDK with its virtual machine powered off, that guest OS becomes unbootable.

Renaming a Disk

The function to rename virtual disk files is `VixDiskLib_Rename()`. It takes two arguments: the old and the new VMDK filenames.

```
vixError = VixDiskLib_Rename(oldGlobals.diskpath, newGlobals.diskpath);
```

Effects of Renaming a Virtual Disk

The server expects VMDK files of its guest OS virtual machines to be in a predictable location. Any file accesses that occur during renaming might cause I/O failure and possibly cause a guest OS to fail.

Managing Child Disks

In the Virtual Disk API, redo logs are managed as a parent-child disk chain, each child being the redo log of disk changes made since its inception. Trying to write on the parent after creating a child results in an error. The library expects you to write on the child instead. See [Attach Child to Parent Disk](#) for a diagram.

Create Redo Logs

A redo log is created by taking a virtual machine snapshot, which contains both disk data and virtual machine state. On hosted disk only, `VixDiskLib_CreateChild()` creates a redo log without virtual machine state.

You could write a simple application to create redo logs, or snapshots on managed disk, at 3:00 AM nightly. (although multiple snapshots have a performance impact). When you create a redo log while the virtual machine is running, the VMware host re-arranges file pointers so the primary VMDK, `<vmname>.vmdk` for example, keeps track of redo logs in the disk chain. Use the disk chain to re-create data for any given day.

To re-create data for any given day

Procedure

- 1 Locate the `<vmname>--<NNN>.vmdk` redo log for the day in question.
`<NNN>` is a sequence number. You can identify this redo log or snapshot by its timestamp.
- 2 Initialize the virtual disk library and open the redo log to obtain its parent handle.
- 3 Create a child disk with the `VixDiskLib_Create()` function, and attach it to the parent:

```
vixError = VixDiskLib_Attach(parent.Handle(), child.Handle());
```

4 Read and write the virtual disk of the attached child.

This is just an example. On managed disk, multiple snapshots are not recommended for performance reasons. Backup software on vSphere usually takes a snapshot, saves data to backup media, then deletes the snapshot.

Virtual Disk in Snapshots

The Virtual Disk API provides the following features to deal with the disk component of snapshots:

- Attaching an arbitrary child in a disk chain
- Opening read-only virtual disks
- Ability to open snapshot disk on ESXi hosts through VMware vCenter

Windows 2000 Read-Only File System

Another use of parent-child disk chaining is to create read-only access for Windows 2000, which has no option for mounting a read-only file system.

In [Figure 6-1](#), the gray circle represents a virtual disk that must remain read-only because it has children. In this example, you want the Windows 2000 virtual machine to use that virtual disk, rather than the newer ones C1 and C2. Create new child disk RO, attach to the gray virtual disk as parent, and mount RO as the (mostly empty) read-only virtual disk of the Windows 2000 guest OS.

Figure 6-1. Attaching Virtual Read/Write Disk for Windows 2000

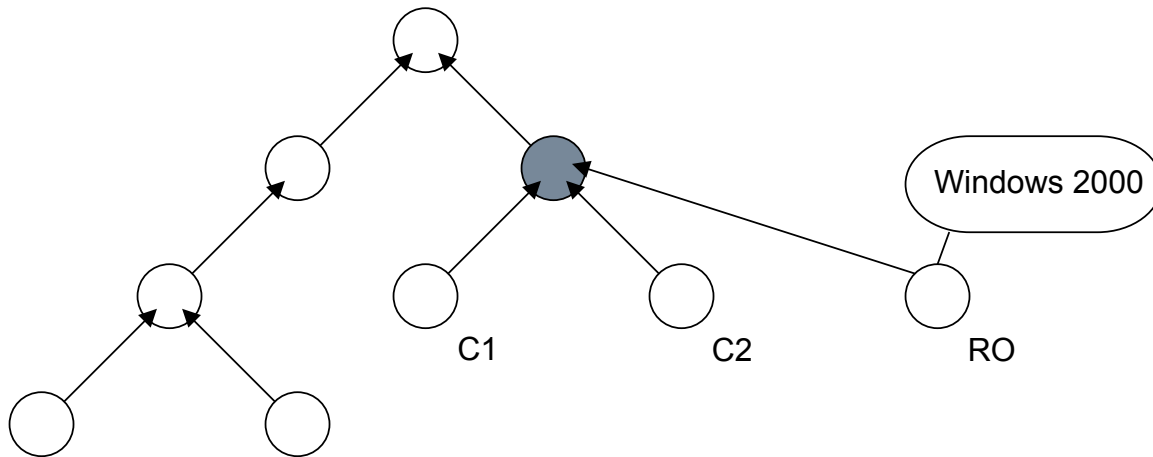

RDM Disks and Virtual BIOS

This section outlines low-level procedures for restoring raw device mapping (RDM) disks and NVRAM.

Restore RDM Disks

Backing up and restoring RDM disks presents unusual challenges. The original backed-up RDM configuration might not apply, and is probably not appropriate, if users restore:

- A virtual machine to a different host or datastore.
- A virtual machine that was deleted, when its originally mapped RDM was also deleted, or the containing LUN was repurposed and rewritten.
- The RDM to a different virtual machine, even if that virtual machine is on the same host and datastore. Users might do this to access files on the disk, or to test a restore.

When performing a proxy backup of an RDM disk, you must present the same LUN ID to both the ESXi host and the proxy server. (This restriction does not apply to VMFS disk because the virtual disk library reads the VMFS header and matching UUID. But for RDM the host and proxy require the same LUN ID.)

Restoring RDM disks is appropriate if the original virtual machine's VMX file and disk mapping is no longer available, but the LUN containing the RDM is still available. In this case, the RDM image on the LUN might still be valid, so it does not need to be restored. If this is true, do not make changes to the RDM configuration during your restore operations. Instead, complete the restore process in two phases:

- Restore the virtual machine configuration (VMX) and system disk. This restores the virtual machine, but does not restore the RDM.
- Add the RDM disk to the virtual machine. After doing so, you can complete normal restore operations on the RDM disk.

Alternatively, it is possible to create a virtual machine that can host the RDM disk and access its contents. After you create the virtual machine, restore its virtual machine configuration (VMX) from backup, and then restore any selected disks.

Restore the Virtual BIOS or UEFI

The `.nvram` file stores the BIOS or UEFI customizations of a virtual machine. Usually the only important items in this file are the boot drive setting and the boot order (in the case of multiple virtual disks).

Newer releases of vSphere can change the boot order using extended attribute settings, so boot order no longer must be stored in the `.nvram` file. However some users want to preserve a virtual machine's serial port settings in the `.nvram` file, and possibly other items, so applications should back up and restore this information.

To back up and restore NVRAM:

Procedure

- 1 For each virtual machine, make a separate copy of the `.nvram` file.
- 2 Back up each virtual machine using standard methods.
- 3 If necessary, restore the virtual machine using standard methods.

- 4 Overwrite the virtual machine's `.nvram` file with the saved copy of the original `.nvram` file.

Important VMware now recommends saving the `.nvram` file as part of virtual machine backup, a change in recommendation since vSphere 4.1.

Interfacing With VMware vSphere

This section provides pointers to other vSphere programming interfaces.

The VIX API

The VIX API was a popular developer interface for VMware Workstation and other hosted products. It has been deprecated for vSphere. See the VMware developer documentation for information about the VIX API:

<http://www.vmware.com/support/developer/vix-api>

The *VIX API Reference* guide includes function reference pages for C++, Perl, and COM (component object model) for Microsoft C#, VBScript, and Visual Basic. Most reference pages include helpful code examples. Additionally, the [vix-api](#) Web guide includes examples for power on and off, suspending a virtual machine, taking a snapshot, guest operations, virtual machine discovery, and asynchronous callbacks.

Virus Scan all Hosted Disk

Suppose you want to run the antivirus software presented in [Scan VMDK for Virus Signatures](#) for all virtual machines hosted on a VMware Workstation. Here is the high-level algorithm for an VIX-based application that would scan hosted disk on all virtual machines.

To virus scan hosted virtual disk:

Procedure

- 1 Write an application including both the Virtual Disk API and the VIX API.
- 2 Initialize the virtual disk library with `VixDiskLib_Init()`.
- 3 Connect VIX to the Workstation host with `VixHost_Connect()`.
- 4 Call `VixHost_FindItems()` with item-type (second argument) `VIX_FIND_RUNNING_VMS`.
This provides to a callback routine (fifth argument) the name of each virtual machine, one at a time. To derive the name of each virtual machine's disk, append `".vmdk"` to the virtual machine name.
- 5 Write a callback function to open the virtual machine's VMDK.
Your callback function must be similar to the `VixDiscoveryProc()` callback function shown as an example on the `VixHost_FindItems()` page in the *VIX API Reference Guide*.
- 6 Instead of printing "Found virtual machine" in the callback function, call the `DoVirusScan()` function shown in [Scan VMDK for Virus Signatures](#).

- 7 Decontaminate any infected sectors that the virus scanner located.

The vSphere Web Services API

The VMware vSphere Web Services (WS) API is a developer interface for ESXi hosts and vCenter Server. See the VMware developer documentation for information about the vSphere WS API:

<http://www.vmware.com/support/developer/vc-sdk>

The *Developer's Setup Guide* for the VMware vSphere WS SDK has a chapter describing how to set up your programming environment for Microsoft C# or Java. Some of the information applies to C++ also.

The *Programming Guide* for the vSphere SDK contains some sample code written in Microsoft C# but most examples are written in Java, and based on the JAX-WS development framework.

ESXi hosts and the VMware vSphere WS API use a programming model based on Web services, in which clients generate Web services description language (WSDL) requests that pass over the network as XML messages encapsulated in simple object access protocol (SOAP). On ESXi hosts or vCenter Server, the vSphere layer answers client requests, usually passing back SOAP responses. This is a different programming model than the object-oriented function-call interface of C++ and the VIX API.

Virus Scan All Managed Disk

Suppose you want to run the antivirus software presented in [Scan VMDK for Virus Signatures](#) for all virtual machines hosted on an ESXi host. Here is the high-level algorithm for a VMware vSphere solution that can scan managed disk on all virtual machines.

To virus scan managed virtual disk:

Procedure

- 1 Using the VMware vSphere Perl Toolkit, write a Perl script that connects to a given ESXi host.
- 2 Call `Vim::find_entity_views()` to find the inventory of every `VirtualMachine`.
- 3 Call `Vim::get_inventory_path()` to get the virtual disk name in its appropriate resource.

The VMDK filename is available as `diskPath` in the `GuestDiskInfo` data object.

- 4 Using Perl's `system(@cmd)` call, run the extended `vixDiskLibSample.exe` program with `-virus` option.

For ESXi hosts you must specify `-host`, `-user`, and `-password` options.

- 5 Decontaminate any infected sectors that the virus scanner located.

Read and Write VMDK Using vSphere API

The VMware vSphere Web Services API (version 2 and later) offers some methods to manage VMDK files. The `VirtualDiskManager` managed object defines more than a dozen methods similar to those in the Virtual Disk API documented here.

For more information, navigate to the latest VMware vSphere documentation center on the Web, search for `VirtualDiskManager`, and follow the specific link. At top of page you can click Local Methods to see a list of all methods defined by the `VirtualDiskManager` managed object.

`VirtualDiskManager` methods were not heavily used, and have not been updated to support object oriented file systems such as vSAN and VVol, or storage profile based management (SPBM).

First Class Disk (FCD) Backup

First Class Disk (FCD), also known as Improved Virtual Disk, provides storage lifecycle management on virtual disks, independent of virtual machines. An FCD may be created natively using the FCD interfaces or an existing virtual disk may be promoted to an FCD.

First Class Disk is a named virtual disk not associated with a VM. The vSphere API for handling FCD is called VSLM, virtual storage lifecycle management.

In vSphere 6.5, VDDK supported the backup of FCD in attached mode, but not in detached mode. To back up FCD, programs had to attach the FCD to a dummy VM (such as one without a guest OS) and then back up the VM.

In vSphere 6.7, VDDK supports the backup of detached FCD, in any transport mode. Detached FCD is neither related to nor attached to a VM. It is identified by a combination of its UUID and the datastore ID where it resides. An FCD must be attached to a VM for regular I/O, but not for snapshot based backup.

First Class Disks are identified by UUID. This UUID is globally unique and the primary identifier for the FCD. The UUID remains valid even if its FCD is relocated or snapshotted. FCD operations are performed using the `VStorageObjectManagerBase` managed object, extended for either ESXi hosts or vCenter Server. See the *vSphere API Reference* for details.

FCD Workflows and Operations

Create and Delete: FCDs can be created using the `createDisk_Task` method. An existing VMDK can be promoted to FCD using the `registerDisk` method. Once a disk has been registered as an FCD it cannot be unregistered, however registering a disk as an FCD has no impact other than enabling the VSLM APIs to manage them.

Snapshot: FCD snapshots use the same underlying mechanisms as regular snapshots and have the same restrictions as regular snapshots. FCD snapshots are independent of VM snapshots. Each FCD snapshot receives a separate snapshot ID. Snapshots are managed using the `VStorageObjectManager` specific `createSnapshot_Task` and `deleteSnapshot_Task` methods. You can revert an FCD to a given snapshot using the `RevertVStorageObject_Task` method. Reverting an FCD removes all snapshots after the selected snapshot. To access data at the time of the snapshot without discarding subsequent snapshots, you can use the `VStorageObjectManagerCreateDiskFromSnapshot` method or VADP restore.

Backup and Restore: FCDs that are not attached to VMs can be backed up using the VADP interfaces. For backup applications, the best practice is to back up VMDKs and FCDs attached to the VMs, and also back up FCDs that are not attached to a VM.

Discovering FCDs for Backup

FCDs can be listed on a per-datastore basis. The recommended practice is to iterate across the list of datastores from vCenter, get the FCDs for each datastore, then perform a backup of each FCD. VADP can back up both attached and detached FCDs.

Use the Datacenter managed object's datastore property to list all datastores in a datacenter. For each datastore, use the `listVStorageObject` method to list the FCDs. For each FCD, use the `VStorageObject.getConfig.getId` API to retrieve the FCD's ID. The FCD ID is used in `connParams->vStorageObjSpec.id` below. The FCD snapshot ID is used in the `connParams->vStorageObjSpec.ssid` to specify the snapshot to back up from.

New Connect Parameters and Functions

VDDK 6.7 has a new union in the `VixDiskLibConnectParams` structure, and new function calls to allocate and free the structure, `VixDiskLib_AllocateConnectParams()` and `VixDiskLib_FreeConnectParams()`. The new typedef is a union of:

- `vmxSpec`, the traditional specification string for a VM.
- `VixDiskLibVStorageObjectSpec` specifying the FCD's UUID, datastore MoRef, and snapshot UUID.

`VixDiskLib_AllocateConnectParams()` is the recommended way to allocate an instance of `VixDiskLibConnectParams`. Programs can allocate `VixDiskLibConnectParams` as before, although then they cannot use new features in 6.7 such as detached FCD.

Except for connection parameters, VDDK code remains the same. All transport modes may be used. Here is sample C++ code to allocate and initialize the connect parameters structure:

```
auto connParams = VixDiskLib_AllocateConnectParams();
connParams->specType = VIXDISKLIB_SPEC_VSTORAGE_OBJECT;
connParams->vStorageObjSpec.id = "XXXXXX" // FCD UUID
connParams->vStorageObjSpec.datastoreMoRef = "datastore-N" // datastore
connParams->vStorageObjSpec.ssid = "XXXXXX" // FCD snapshot UUID
...
VixDiskLib_FreeConnectParams(connParams); // free connect params near end
```

For a `vmxSpec`, here is a sample of legacy C++ code, and a revision:

```
// old:
VixDiskLibConnectParams connParams;
connParams.vmxSpec = "moref=vm-XX"; // vm moref
// new:
auto connParams = VixDiskLib_AllocateConnectParams();
connParams->specType = VIXDISKLIB_SPEC_VMX;
connParams->vmxSpec = "moref=vm-XX"; // vm moref
...
VixDiskLib_FreeConnectParams(connParams); // free connect params near end
```

Subsequently, `VixDiskLib_Open` ignores its disk path parameter because path location is determined by `VixDiskLibVStorageObjectSpec`. The snapshot UUID is specified in `VixDiskLibVStorageObjectSpec`, so the disk path is invisible to the customer anyway. Consequently programs can pass `NULL` as the disk path parameter to `VixDiskLib_Open`. Programs can also pass an FCD's UUID as the path parameter:

```
VixError
VixDiskLib_Open(const VixDiskLibConnection connection,
                const char *path,
                uint32 flags,
                VixDiskLibHandle *diskHandle);
```

However for the `VixMntapi` open disks call, passing a null `diskNames` parameter may cause a crash. Programs should pass the FCD's UUID only, and specify `numberOfDisks = 1`.

```
VixError
VixMntapi_OpenDisks(VixDiskLibConnection connection,
                    const char *diskNames[],
                    size_t numberOfDisks,
                    uint32 openFlags,
                    VixDiskSetHandle *handle);
```

FCD Managed Objects and Tasks

The following managed objects and tasks are available in vSphere for manipulating FCD storage. For details, see the *vSphere Web Services API Reference* on <https://code.vmware.com> under the vSphere Management SDK.

- `HostVStorageObjectManager` manages FCD when connected to an ESXi host.
- `VcenterVStorageObjectManager` manages FCD when connected to a vCenter Server.
- `VirtualMachine.AttachDisk_Task()` attaches FCD to a VM.
- `VirtualMachine.DetachDisk_Task()` detaches FCD from the VM.

Behavior of FCD With Changed Block Tracking

The behavior of FCD with changed block tracking (CBT) differs from that of a regular VMDK disk.

- 1 Attaching an FCD with CBT disabled (the default) to a VM with CBT enabled causes CBT on the FCD to become enabled. However, detaching that FCD from the VM does not disable CBT.
- 2 Attaching an FCD with CBT enabled to a VM with CBT disabled throws an error, unless the FCD is attached as "independent nonpersistent" disk.

Use `ReconfigVM_Task` and connect the disk with the `diskMode` set to `independent_nonpersistent` in the backing info. (`VirtualDiskSeSparseBackingInfo`, `VirtualDiskFlatVer2BackingInfo`, `VirtualDiskRawDiskMappingVer1BackingInfo` and `VirtualDiskSparseVer2BackingInfo` support this mode.)

Behavior of FCD with vMotion

An FCD can be attached to more than one VM.

When your program calls `VixDiskLib_PrepareForAccess`, VDDK disables the vSphere API method `RelocateVM_Task` for all attached VMs, one after another. If an error occurs while disabling, VMs whose relocate method was disabled remain disabled, whereas subsequent VMs can still be relocated.

Programs should call `VixDiskLib_EndAccess` to re-enable the relocate method, regardless of `VixDiskLib_PrepareForAccess` return status. Otherwise vMotion or Storage vMotion could fail for the remaining disabled VMs.

Code Sample for Connect Parameters

In the development kit, see lines in the `vixDiskLibSample.cpp` program where connection parameters are allocated with the `VixDiskLib_AllocateConnectParams()` call.

In vSphere 6.7 and later, the Web Services SDK contains FCD code samples in Java for creating, attaching, detaching, and deleting FCD.

In the vSphere 6.7 U2 release, Container Native Storage (CNS) supports FCD, and support for more solutions will be added in the future.

Backing Up Virtual Disks in vSphere

7

This chapter documents how to write backup and restore software for virtual machines running in vSphere, and contains the following sections about the vSphere Storage APIs – Data Protection (VADP):

For an overview of backup, and help designing your top-level program structure, read the first section below. For details about implementing low-level backup code, read the remaining sections. You should be familiar with virtual machines, snapshots, ESXi, vCenter, and Java.

This chapter includes the following topics:

- [Design and Implementation Overview](#)
- [Low Level Backup Procedures](#)
- [Low Level Restore Procedures](#)
- [Tips and Best Practices](#)
- [Windows Backup Implementations](#)
- [Linux Backup Implementation](#)

Design and Implementation Overview

On vSphere, backups are usually done by taking a snapshot, to efficiently obtain a static image of the virtual machine. Snapshots are a view of a virtual machine at a certain point in time, and enable quick and clean backup operation. Snapshots also provide an incremental backup mechanism called changed block tracking.

To back up virtual machines on vSphere, VMware recommends a two-language solution. First use Java to code the backup program that contacts the host, takes a temporary snapshot, records virtual machine configuration, and (later) deletes the snapshot. Then use C++ or C to code the VDDK program that transfers virtual disk data from the snapshot to backup media.

For restore, VMware recommends a two-language solution. First use Java to code the program that instructs the virtual machine to halt, or re-creates the target virtual machine from recorded configuration. Then use C or C++ to code the VDDK program that transfers saved data from backup media to virtual disk.

The Backup Process

These are the high-level steps to back up a virtual machine running in vSphere:

Procedure

- 1 Connect to the ESXi host containing the virtual machine targeted for backup.
A side-effect of this step is determining the arrangement and description of virtual machines on the host.
- 2 Tell the host to take a snapshot of the target virtual machine, using the vSphere API. Use the `quiesce` flag, but not the `memory` flag, which is incompatible with `quiesce`. The virtual machine continues to run, while the snapshot provides a static (quiesced) view.
- 3 Capture the virtual disk data and virtual machine configuration information (`vim.vm.ConfigInfo`).
- 4 On the ESXi host, use the VDDK (programming in C or C++) to open and read the virtual disk and snapshot files. Copy them to backup media, along with configuration information.
- 5 Tell the host to delete the backup snapshot, using the vSphere API.

Communicating With the Server

In a typical vSphere deployment with many ESXi hosts, an instance of vCenter Server manages the ESXi hosts, and can move virtual machines from host to host (vMotion) to balance load and possibly save electricity by powering off an ESXi host. VMware therefore recommends that backup applications communicate with the vCenter Server instead of with individual ESXi hosts.

The vCenter Server provides location transparency for vSphere Web Services developers. The vCenter Server tracks virtual machines as they move (through vMotion) from one ESXi host to another, and vCenter Server directs SDK operations to the ESXi host that currently runs a virtual machine. Using the vSphere Web Services API, it is possible to back up all the virtual disks associated with a virtual machine.

The handling of the vCenter or an individual ESXi host is essentially equivalent when using the vSphere SDK. With vCenter management, there is no need to contact individual ESXi hosts directly. The remainder of this chapter uses the term vSphere to indicate either a vCenter Server or an ESXi host.

To reduce the resources used by vSphere, VMware recommends that the number of connections (or Sessions) be minimized. It is in the best interests of any program that communicates with vSphere to create one Session and share it with all elements of the program that need to exchange information with vSphere. This means that if your program supports multiple threads, your program should multiplex the use of connection objects by use of access control locks (mutex and the like).

It is also important that all vSphere SDK operations proceed from one instance of the “Session” object that your application requests after logging into vSphere. Using the vSphere API your application can create objects that are “Session specific” and therefore would not be known to other portions of your application that might use a different Session.

Information Containers as Managed Objects

VMware documentation introduces you to the concept of the managed object and its handle, called a managed object reference (moRef). You might be tempted to get configuration and status information of managed objects using a piecemeal approach. This has the severe disadvantage of creating a lot of chatter over the server connection, so it is very slow. A mechanism has been created to provide status information efficiently: the `PropertyCollector`, discussed in [PropertyCollector Data](#).

More About Managed Objects

The documentation for the vSphere API and object model introduces a large number of managed objects. There are five basic types of managed objects that describe the organization of a server. Other managed objects can be considered as details expanding on these five basic types:

- Folder
- Datacenter
- ComputeResource
- ResourcePool
- VirtualMachine

It is a characteristic of all managed objects that they have a moRef to the managed object that serves as the parent to the managed object. This parent moRef allows you to reconstruct the object hierarchy exposed by the vSphere SDK. In general the hierarchy is a tree-like structure along the lines of:

Root Folder > Datacenter > ComputeResource > ResourcePool > VirtualMachine

There are variations on this theme, depending on whether you connect to vCenter or directly to an ESXi host, but the overall organization is like the structure above. Each managed object also has a Name property.

The virtual machine that you want to back up, and the snapshot you take of it (the extensible managed object `VirtualMachineSnapshot`) are both designated by their moRef.

Managed Object References

A managed object reference (moRef) is actually a handle and not the managed object itself. While it is certain that a moRef always contains a unique value, the unique value is only relative to the instance of vSphere to which you are connected. For example, if vCenter Server manages a cluster of ESXi hosts, each ESXi host maintains its own managed object reference namespace and the vCenter must maintain a managed object reference namespace representing all of its servers. So when an ESXi host is represented by a vCenter, the vCenter must ensure that the managed object references are unique. The vCenter accomplishes this by creating unique managed object reference names inside its own namespace, which differ from the names that ESXi uses for the same managed objects.

A vSphere instance (vCenter or ESXi) tries to keep the moRef for a virtual machine consistent across sessions, however consistency is not guaranteed. For example, unregistering and reregistering a virtual machine could result in a change to the moRef for the virtual machine. Thus, it is a bad idea to store a moRef and expect it to work correctly in future sessions, or with a different vCenter Server.

Unique ID for a Different vCenter

On one vCenter Server, the moRef uniquely identifies a virtual machine. If you need to track and inventory virtual machine backups across multiple vCenter Servers, you can use moRef together with instanceUuid. You can see the instanceUuid at the following browser path:

```
https://<vcserver>/mob/?moid=ServiceInstance&doPath=content.about
```

For direct connections to ESXi, the host address and moRef uniquely identify a virtual machine. However this moRef could be different from the one that vCenter Server returns, hence the fallback to instanceUuid. The instanceUuid was new in VMware vSphere 4.0. In previous releases, the fallback was to Uuid.

Gathering Status and Configuration Information

To save configuration of a virtual machine so you can restore it later, you can use the PropertyCollector to get the virtual machine configuration.

The PropertyCollector is the most efficient mechanism to specify, at the top level, all of the managed objects that are of interest to your application. It has methods for providing updates that indicate only changes to the previous state of these objects. There are two mechanisms for acquiring these updates:

- Polling – Check for changes. The result is either “no change” or an object containing the changes. One advantage of this mechanism is that it involves no network traffic except for a poll request and reporting.
- Wait for updates – “Wait for updates” is basically a blocking call to the PropertyCollector. This is only useful if you dedicate a program thread waiting for the call to unblock. The advantage of this mechanism is that there is no traffic on the communications thread unless something must be reported.

The PropertyCollector is powerful but requires great attention to detail. Backup-related features of the PropertyCollector are covered in [Low Level Backup Procedures](#) of this document. The next section provides some background about PropertyCollector.

PropertyCollector Data

This document assumes that you want to keep up with changes in the configuration of the vCenter Server, and therefore plan to use the update tracking capability of the PropertyCollector.

The `PropertyCollector` requires two fairly complex arguments: the `PropertySpec` and the `ObjectSpec`. The `ObjectSpec` contains instructions to the `PropertyCollector` describing where to look for the desired data. Because configuration information in vSphere is organized like a directory tree, the `ObjectSpec` must describe how to traverse the tree to obtain the desired information. The net result is a complex, nested, and recursive list of instructions. Fortunately, once you have determined the location of all the desired information, the `ObjectSpec` needed to determine the layout of a vSphere object hierarchy can be a static unvarying object. See the code example in section [Understanding an ObjectSpec](#).

The `PropertySpec` is a list of desired property information. Formulating a list that includes all of the desired information can take some effort to compile, but once determined, this can be a static object also.

The data returned from the `PropertyCollector` is a container class called `PropertyFilterUpdate`, which contains an `objectSet` with an item-by-item list of changes to object properties. Every item in this container is identified with one of the following keys: `enter` (add), `leave` (delete), and `modify`. On the first data request, every data item is included, and “enter” is marked for every data item.

The `PropertyCollector` presents its results in what amounts to random order. Since all managed objects have a “parent” property, you can reconstruct the configuration hierarchy by building a tree in memory, using the parent identification to organize. The root folder is identified as the only folder without a parent.

Useful Property Information

In the data returned from `PropertyCollector`, you can find most of the information that is useful for backup in the Virtual Machine managed object, including the following:

- Virtual Disks – names, types, and capacities.
- Virtual Machine Type and Configuration – Whatever would be useful in (re)creating a virtual machine. This list might include such information as memory size and number of CPUs.
- Display Names – These names appear in VMware products such as the vSphere Client. You should keep track of these names and correlate them for consistency between your product and VMware products.

VMware supports many virtual disk implementations. The disk implementation type is important because:

- On restore, you should re-create virtual disk with the same disk type as the original virtual machine used.
- A disk backed by a pass-through raw device mapping (RDM) mostly bypasses the ESXi storage stack. You cannot make a snapshot of this virtual disk type. Therefore, you cannot back up pass-through RDM disk using the snapshot method described in this document.

For more information about the Java APIs, read the first several chapters of the *VMware vSphere Web Services SDK Programming Guide*, and related pages of the Web-based *VMware vSphere API Reference Documentation*. Both are available at <http://www.vmware.com/support/developer/vc-sdk>. Examples in this chapter assume that you have set up the vSphere SDK as described in documentation.

Doing a Backup Operation

After your program obtains information about what is available to back up, it can perform a backup. The three steps to the backup process are:

- [Create a Temporary Snapshot on the Target Virtual Machine](#)
- [Extract Backup Data from the Target Virtual Machine](#), and save configuration information.
- [Delete the Temporary Snapshot](#)

Prerequisites for Backup

To complete a backup, the calling program requires the permissions shown in [Table 7-1](#).

Table 7-1. Required Permissions to Complete a Backup

Privilege Category	Privilege Subcategory	Privilege
Virtual Machine	Provisioning	Allow Virtual Machine Download
	State	Create Snapshot
		Remove Snapshot
	Configuration	Disk Lease

Create a Temporary Snapshot on the Target Virtual Machine

The low-level procedure for creating a snapshot of a virtual machine is documented in the section [Creating a Snapshot](#). Set the `quiesce` flag `True` to make the file system quiescent, otherwise the snapshot might represent a transitional system state, with inconsistent data. Restoring such data might be destructive.

Another flag named `memory` allows you to include in the snapshot a dump of the powered on virtual machine's in-memory state. This is not needed for backup, so set this flag to `False`.

Changed Block Tracking

This feature, first available in vSphere 4, provides the foundation for incremental (or differential) backup of virtual disks. Your application can back up only changed data as indicated by the `QueryChangedDiskAreas` method. Virtual machines with virtual hardware version 7 and later support changed block tracking. These virtual machines contain `changeTrackingSupported` in the `capability` field of the `VirtualMachine` managed object. See [Changed Block Tracking on Virtual Disks](#) for details.

Extract Backup Data from the Target Virtual Machine

Associated with the snapshot you just created are “versions” of the virtual disks. To identify these disks, you obtain a `moRef` to the snapshot you just created. From this snapshot `moRef`, you can extract the disk names and paths. How to do this is demonstrated in section [Backing Up a Virtual Disk](#).

To read the data in a virtual disk, it is necessary to use the `VixDiskLib`. This library isolates the programmer from the details of extracting data from a virtual disk and its redo logs. For example, when doing backup you call functions `VixDiskLib_Open()` and `VixDiskLib_Read()`, among others. `VixDiskLib` allows access to disk data on sector boundaries only; the transfer size is some multiple of the disk sector size.

When accessing disks on ESXi hosts, `VixDiskLib` release 1.0 transferred virtual disk data over the network. Later `VixDiskLib` releases contain API enhancements so you can request more efficient data paths, such as direct SAN access or HotAdding disks to a virtual backup appliance. These efficient data paths requires minor code changes, such as calling `VixDiskLib_ConnectEx()` instead of plain connect.

Part of virtual disk information is metadata: a number of key/value pairs describing configuration of the virtual disk. Metadata information can be extracted from a virtual disk using the `VixDiskLib` functions `VixDiskLib_GetMetadataKeys()` and `VixDiskLib_ReadMetadata()`. You should save metadata keys along with the backup, in case you need to re-create the virtual disk.

The `VixDiskLib` API allows a backup application to perform a full backup of a virtual machine. The newer `VixMntapi` library can extract information about a guest operating system from its virtual disks, so your backup application can determine the type of operating system that is involved. This allows mounting the volumes to device nodes, so your application can perform file-oriented backups and restores.

Delete the Temporary Snapshot

As the last part of the backup process, you should delete the temporary snapshot. It is no longer needed, worsens virtual machine performance, and takes up storage space that could be put to better use.

Restore a Virtual Machine

Your software can follow one of two restore scenarios: either revert to a saved state, or disaster recovery:

To bring an existing virtual machine to a previous state

- 1 Connect to the server and command it to halt and power off the target virtual machine.
- 2 Use the server to gain access to the virtual disks. With SAN transport (but not HotAdd or NBDSSL) you must create a snapshot before restoring data.
- 3 Transfer the disk images from backup using `VixDiskLib`. Revert-to and delete the snapshot, if created.

To completely re-create a virtual machine (disaster recovery)

- 1 Connect to the server.
- 2 Command the server to create a new virtual machine and its virtual disks using the configuration information saved from `vim.vm.ConfigInfo` during backup.
- 3 Transfer virtual disk data to the newly created virtual disks using `VixDiskLib`. Virtual disk data includes disk formatting information, so you do not need to build any kind of file system on the virtual disks.

Doing a Restore Operation

The two scenarios of restore operation are described below.

- [Restore an Existing Virtual Machine to a Previous State](#)
- [Create a New Virtual Machine](#)

Prerequisites for Restore

To complete a restore, the calling process requires the permissions in [Table 7-2](#).

Table 7-2. Required permissions to complete a restore

Privilege Category	Privilege Subcategory	Privilege
Virtual Machine	Inventory	Create
		Remove
	Configuration	Settings
		Change Resource
Resource		Assign Virtual Machine to Resource Pool

For security reasons, programs are not granted write access to the disks of a running virtual machine. Before you shut it down, you should determine the run-state of the virtual machine.

Run-state information is available from the `PropertyCollector`, and if you keep this information up-to-date, your application already knows the run-state of the virtual machine. To change the run-state you must have the `moRef` of the virtual machine. Use this `moRef` in a `PowerOnVM_Task` call through the server connection. For virtual machine shutdown, call the `PowerOffVM_Task` method.

Restore an Existing Virtual Machine to a Previous State

The following steps restore a virtual machine to a certain saved state:

Procedure

- 1 Shut down the virtual machine (if it is not already shut down).
- 2 For SAN transport mode, a snapshot is required for restoring virtual disk data, and writes must go to the base disk only. The restore snapshot is optional (not necessary) for NBD(SSL) and HotAdd transport modes. On VVol datastores, if a snapshot was taken, writes must go to the leaf disk because the snapshot volume is read-only.
- 3 Restore contents of the virtual disk(s). If there were no pre-existing snapshots at backup time, just the snapshot just created, restore only the base disks.

Restoring disk data requires that you obtain the current names of virtual disks. This process is similar to the one described in [Extract Backup Data from the Target Virtual Machine](#), except in this case you obtain this information directly from the virtual machine and not from a snapshot. The target for the saved disk data must be the actual disk name (including any sequence number) because the current incarnation of a virtual machine may be derived from one or more snapshots.

Restoring disk data requires use of `VixDiskLib`. The `VixDiskLib_Write()` function opens the virtual disks so your program can write data. `VixDiskLib` functions transfer data to even-sector boundaries only, and transfer length must be an even multiple of the sector size.

The virtual disk already exists, so it is not necessary to restore the disk configuration information mentioned in [Extract Backup Data from the Target Virtual Machine](#).

- 4 With SAN transport mode, revert-to and delete the snapshot that you created in step 2. Failing to perform this step with SAN mode could yield a virtual machine that cannot be powered on.

Create a New Virtual Machine

The process of building a virtual machine from backup data involves the following steps:

Procedure

- 1 Create the virtual machine.

To create a new virtual machine, you use the information about virtual machine configuration that you derived and saved during the backup process. You might allow users of restore software an opportunity to rename the virtual machine during recovery in case they want to clone or move the virtual machine. Also you might consider offering them an opportunity to change virtual machine layout (for instance, storing virtual disks on a different datastore). Creating the virtual disks is also done at the time when you create the virtual machine. This process is fairly complicated. See the section [Low Level Backup Procedures](#) for details.

- 2 Restore the virtual disk data.

This process is similar to restoring the contents of virtual disks (step 3 under [Restore an Existing Virtual Machine to a Previous State](#)) with the following exception: you must call the `VixDiskLib_WriteMetadata()` function to write all the disk configuration key/value data into the virtual disk before restoring any backed-up data to the virtual disk. Then call `VixDiskLib_Write()` to restore the virtual disk data, as described in step 3.

- 3 Power on the virtual machine.

Access Files on Virtual Disks

It might be necessary for a backup application to access individual files or groups of files on the virtual disks. For example, data protection applications might need to restore individual files on demand.

You can find the interfaces to accomplish this in the `VixMntapi` library associated with `VixDiskLib`. The `VixMntapi` library allows disks or volumes of a virtual machine to be mounted and examined as needed. `VixMntapi` provides access at the file system level, whereas `VixDiskLib` provides access at the sector level.

To mount a virtual disk

Procedure

- 1 Locate the path names of all the virtual disks associated with a snapshot.

- 2 Call `VixDiskLib_Open()` to open all of these virtual disks. This gives you a number of `VixDiskLib` handles, which you should store in an array.
- 3 Call `VixMntapi_OpenDiskSet()` to create a `VixDiskSetHandle`, passing in the array of `VixDiskLib` handles that you created in step 2.
- 4 Pass `VixDiskSetHandle` as a parameter to `VixMntapi_GetVolumeHandles()` to obtain an array of `VixVolumeHandle` pointers to all volumes in the disk set.
- 5 Call `VixMntapi_GetOsInfo()` to determine what kind of operating system is involved, and decide where important pieces of information are to be found.
- 6 For important volumes, call `VixMntapi_MountVolume()` then `VixMntapi_GetVolumeInfo()`, which reveals how the volume is set up. (Unimportant volumes include swap partitions.)
- 7 If you need information about how the guest operating system sees the data on this volume, you can look in the data structure `VixVolumeInfo` returned by `VixMntapi_GetVolumeInfo()`. For example, `VixVolumeInfo::symbolicLink`, obtained using `VixMntapi_GetVolumeInfo()`, is the path on the proxy where you can access the virtual disk's file system using ordinary open, read, and write calls.

Once you are done accessing files in a mounted volume, there are `VixMntapi` procedures for taking down the abstraction that you created. These calls are:

- `VixMntapi_DismountVolume()` for each volume handle
- `VixMntapi_FreeOsInfo()` and `VixMntapi_FreeVolumeInfo()`
- `VixMntapi_CloseDiskSet()`

This leaves the `VixDiskLib` handles that you obtained in the beginning; you must dispose of them properly.

More VADP Details

The preceding sections explained how to contact vSphere and extract information from it, and how to back up or restore virtual disks. The following sections cover the same information at a lower level.

Low Level Backup Procedures

This section describes low level details that may be helpful in coding a backup application. It is not the intent of this material to impose a design, but only to serve as a guideline with examples and exposition. The code samples provided below are not complete. They generally lack error handling and ignore critical details.

Communicate with the Server

Connections to the server machine require credentials: user name, password, and host name (or IP address). The following code connects to the server and extracts information useful for manipulating a service:

Procedure

- 1 Create the service instance moRef:

```
ManagedObjectReference svcRef = new ManagedObjectReference();
svcRef.setType("ServiceInstance");
svcRef.setValue("ServiceInstance");
```

- 2 Locate the service:

```
VimServiceLocator locator = new VimServiceLocator();
locator.setMaintainSession(true);
VimPortType serviceConnection = locator.getVimPort("https://your_server/sdk");
```

- 3 Log in to the session manager:

```
ServiceInstanceContent serviceContent = serviceConnection.retrieveContent(svcRef);
ManagedObjectReference sessionManager = serviceInstance.getSessionManager();
UserSession us = serviceConnection.login(sessionManager, username, password, null);
```

The PropertyCollector

The `PropertyCollector` is used in this section to apply the above details to the backup task.

PropertyCollector Arguments

The `PropertyCollector` uses two relatively complicated argument structures. As was mentioned in [PropertyCollector Data](#), these arguments are `PropertySpec` and `ObjectSpec`. `PropertySpec` is a list of the information desired, and `ObjectSpec` is a list of instructions indicating where to find the information. In theory, you could directly address an object using its moRef. In that case an `ObjectSpec` can be very simple. However, getting the initial moRef can be a challenge when a complicated `ObjectSpec` is required. To formulate a complex `ObjectSpec`, you need to understand the structure of the available data. This is complicated by the fact that an `ObjectSpec` can contain recursive elements.

Understanding an ObjectSpec

An `ObjectSpec` is a list of `ObjectSpec` elements, each specifying an object type, and giving a “selection spec” for the object. [More About Managed Objects](#) describes five types of managed objects: Folder, Datacenter, ComputeResource, ResourcePool, and VirtualMachine. VirtualApp (vApp) is a sixth type. You can “traverse” objects, because one managed object leads to another.

- Folder – One of the items contained in the Folder is called `childEntity`, which is a list of moRefs that can contain one of the five managed object types. A Folder can be parent to any of these managed objects.
- Datacenter – This managed object has two items that lead to other managed objects:
 - `hostFolder` – A moRef to a Folder containing a list of ComputeResources comprising a Datacenter.

- `vmFolder` – A `moRef` to a Folder containing the VirtualMachines that are part of the Datacenter. If it is your objective to duplicate the display seen in a vSphere Client GUI, then this Folder is of limited use because it does not describe the ResourcePool that is the parent of a virtual machine.
- `ComputeResource` – A `ComputeResource` is basically hardware. A `ComputeResource` can comprise multiple systems. The hardware represents resources that can be used to implement a `VirtualMachine` object. `VirtualMachine` is a child of `ResourcePool`, which controls the sharing of a physical machine's resources among `VirtualMachine` objects. A `ComputeResource` contains an item named `resourcePool`, which is a `moRef` to a `ResourcePool`.
- `VirtualApp` – A `VirtualApp` (`vApp`) is a collection of `VirtualMachines` that make up a single application. This is a special form of `ResourcePool` (defined below). A `VirtualApp` may have three types of children:
 - `VirtualMachine` – A folder named `vm` contains a list of `moRefs` to child `VirtualMachines`.
 - `resourcePool` – A folder containing a list of `moRefs` pointing to child `ResourcePools` or `VirtualApps`.
 - `VirtualApp` – A `VirtualApp` can be composed of other `VirtualApps`.
 - `ResourcePool` – You can segment the resources of a `VirtualApp` using a `ResourcePool`.
- `ResourcePool` – This managed object contains two child items:
 - `resourcePool` – A folder containing a list of `moRefs` pointing to child `ResourcePools` or `VirtualApps`.
 - `vm` – A list of `moRefs` to child `VirtualMachines` that employ the resources of the parent `ResourcePool`. A `VirtualMachine` always lists a `ResourcePool` as its parent.
- `VirtualMachine` – The `VirtualMachine` is often considered an “end object” – so you do not need to describe any traversal for this object.

The `ObjectSpec` does not have to lead you any farther than the `moRef` of a target object. You can gather information about the managed object itself using the `moRef` and the `PropertySpec`. This is described in detail in the section [Understanding a PropertySpec](#).

A `TraversalSpec` extends `SelectionSpec`, a property of `ObjectSpec`, and contains the following elements:

- `Path` – The element contained in the object that is used to steer traversal.
- `SelectSet` – An array containing either `SelectionSpec` or `TraversalSpec` elements.
- `Skip` – Whether or not to filter the object in the `Path` element.
- `Type` – The type of object being referenced.
- `Name` – Optional name you can use to reference the `TraversalSpec`, inherited from `SelectionSpec`.

`SelectionSpec` is a direct target for traversal, as is `TraversalSpec` (a class extending `SelectionSpec`). It is in the `SelectSet` that recursion can occur.

If you wish to traverse the entire configuration tree for a server, then you need only the “root node” moRef, which is always a Folder. This root folder moRef is available in the property rootFolder of the ObjectSpec service instance content. All of the above goes into this Java code sample.

```
// Traversal objects can use a symbolic name.
// First we define the TraversalSpec objects used to fill in the ObjectSpec.
//
// This TraversalSpec traverses Datacenter to vmFolder
TraversalSpec dc2vmFolder = new TraversalSpec();
dc2vmFolder.setType("Datacenter"); // Type of object for this spec
dc2vmFolder.setPath("vmFolder"); // Property name defining the next object
dc2vmFolder.setSelectSet(new SelectionSpec[] {"folderTSpec"});
//
// This TraversalSpec traverses Datacenter to hostFolder
TraversalSpec dc2hostFolder = new TraversalSpec();
dc2hostFolder.setType("Datacenter");
dc2hostFolder.setPath("hostFolder");
//
// We use the symbolic name "folderTSpec" which will be defined when we create the folderTSpec.
dc2vmFolder.setSelectSet(new SelectionSpec[] {"folderTSpec"});
//
// This TraversalSpec traverses ComputeResource to resourcePool
TraversalSpec cr2resourcePool = new TraversalSpec();
cr2resourcePool.setType("ComputeResource");
cr2resourcePool.setPath("resourcePool");
//
// This TraversalSpec traverses ComputeResource to host
TraversalSpec cr2host = new TraversalSpec();
cr2host.setType("ComputeResource");
cr2host.setPath("host");
//
// This TraversalSpec traverses ResourcePool to resourcePool
TraversalSpec rp2rp = new TraversalSpec();
rp2rp.setType("ResourcePool");
rp2rp.setPath("resourcePool");
//
// Finally, we tie it all together with the Folder TraversalSpec
TraversalSpec folderTS = new TraversalSpec();
folderTS.setName{"folderTSpec"}; // Used for symbolic reference
folderTS.setType("Folder");
folderTS.setPath("childEntity");
folderTS.setSelectSet(new SelectionSpec[]{ "folderTSpec",
                                           dc2vmFolder, dc2hostFolder, cr2resourcePool, rp2rp});
ObjectSpec ospec = new ObjectSpec();
ospec.setObj(startingPoint); // This is where you supply the starting moRef (usually root folder)
ospec.setSkip(Boolean.FALSE);
ospec.setSelectSet(folderTS); // Attach the TraversalSpec we designed above
```

Understanding a PropertySpec

A PropertySpec is a list of individual properties that can be found at places identified by the ObjectSpec and its TraversalSpec. Once the PropertyCollector has a moRef, it can then return the properties associated with that moRef. This can include “nested” properties. Nested properties are properties that can be found inside of properties identified at the top level of the managed object. Nested properties are identified by a “dot” notation.

An example of nested properties can be drawn from the VirtualMachine managed object. A VirtualMachine has the property identified as `summary`, which identifies a `VirtualMachineSummary` data object. The `VirtualMachineSummary` contains property `config`, which identifies a `VirtualMachineConfigSummary` data object. The `VirtualMachineConfigSummary` has a property called `name`, which is a string containing the display name of the VirtualMachine. You can access this name property using the `summary.config.name` string value. To address all the properties of the `VirtualMachineConfigSummary` object, you would use the `summary.config` string value.

The PropertyCollector requires an array of PropertySpec elements. Each element includes:

- **Type** – The type of object that contains the enclosed list of properties.
- **PathSet** – An array of strings containing names of properties to be returned, including nested properties.

It is necessary to add an element for each type of object that you wish to query for properties. The following is a code sample of a PropertySpec:

```
// This code demonstrates how to specify a PropertySpec for several types of target objects:
PropertySpec folderSp = new PropertySpec();
folderSp.setType("Folder");
folderSp.setAll(Boolean.FALSE);
folderSp.setPathSet(new String [] {"parent", "name"});
PropertySpec dcSp = new PropertySpec();
dcSp.setType("Datacenter");
dcSp.setAll(Boolean.FALSE);
dcSp.setPathSet(new String [] {"parent","name"});
PropertySpec rpSp = new PropertySpec();
rpSp.setType("ResourcePool");
rpSp.setAll(Boolean.FALSE);
rpSp.setPathSet(new String [] {"parent","name","vm"});
PropertySpec crSp = new PropertySpec();
crSp.setType("ComputeResource");
crSp.setAll(Boolean.FALSE);
crSp.setPathSet(new String [] {"parent","name"});
PropertySpec vmSp = new PropertySpec();
vmSp.setType("VirtualMachine");
vmSp.setAll(Boolean.FALSE);
vmSp.setPathSet(new String [] {"parent",
                             "name", "summary.config", "snapshot", "config.hardware.device"});

// Tie it all together
PropertySpec [] pspec = new PropertySpec [] {folderSp, dcSp, rpSp, crSp, vmSp};
```

Getting the Data from the PropertyCollector

Now that we have defined `ObjectSpec` and `PropertySpec` (the where and what), we need to put them into a `FilterSpec` that combines the two. An array of `FilterSpec` elements is passed to the `PropertyCollector` (the minimum number of elements is one). Two mechanisms can retrieve data from `PropertyCollector`:

- `RetrieveProperties` – A one-time request for all of the desired properties. This can involve a lot of data, and has no refresh option. `RetrievePropertiesEx` has an additional options parameter.
- Update requests – `PropertyCollector` update requests take two forms: polling and waiting (see below).

Requesting Updates

The update method is the way to keep properties up to date. In either Polling or Waiting, it is first necessary to register your `FilterSpec` array object with the `PropertyCollector`. You do this using the `CreateFilter` method, which sends a copy of your `FilterSpec` to the server. Unlike the `RetrieveProperties` method, `FilterSpec` is retained after `CreateFilter` operation. The following code shows how to set `FilterSpec`:

```
// We already showed examples of creating pspec and ospec in the examples above.
// The PropertyCollector wants an array of FilterSpec objects, so:
PropertyFilterSpec fs = new PropertyFilterSpec();
fs.setPropSet(pspec);
fs.setObjectSet(ospec);
PropertyFilterSpec [] fsa = new PropertyFilterSpec [] {fs};
ManagedObjectReference pcRef = serviceContent.getPropertyCollector();
// This next statement sends the filter to the server for reference by the PropertyCollector
ManagedObjectReference pFilter = serviceConnection.CreateFilter(pcRef, fsa, Boolean.FALSE);
```

If you wish to begin polling, you may then call the function `CheckForUpdates`, which on the first try (when it must contain an empty string for the version number) returns a complete dump of all the requested properties from all the eligible objects, along with a version number. Subsequent calls to `CheckForUpdates` must contain this version number to indicate to the `PropertyCollector` that you seek any changes that deviate from this version. The result is either a partial list containing only the changes from the previous version (including a new version number), or a return code indicating no data has changed. The following code sample shows how to check for updates:

```
String updateVersion = ""; // Start with no version
UpdateSet changeData = serviceConnection.CheckForUpdates(pcRef, updateVersion);
if (changeData != nil) {
    updateVersion = changeData.getVersion(); // Extract the version of the data set
}
// ...
// Get changes since the last version was sent.
UpdateSet latestData = serviceConnection.CheckForUpdates(pcRef, updateVersion);
```

If instead you wish to wait for updates to occur, you must create a task thread that blocks on the call `waitForUpdates`. This task thread would return changes only as they occur and not at any other time. However if the request times out, you must renew it.

Note The order of property retrieval is not guaranteed. Multiple update requests may be needed.

Extracting Information from the Change Data

The data returned from `CheckForUpdates` (or `waitForUpdates`) is an array of `PropertyFilterUpdate` entries. Since a `PropertyFilterUpdate` entry is very generic, here is some code showing how to extract information from the `PropertyFilterUpdate`.

```
// Extract the PropertyFilterUpdate set from the changeData
PropertyFilterUpdate [] updateSet = changeData.getFilterSet();
// There is one entry in the updateSet for each filter you registered with the PropertyCollector.
// Since we currently have only one filter, the array length should be one.
PropertyFilterUpdate myUpdate = updateSet[0];
ObjectUpdate [] changes = myUpdate.getObjectSet();
for (a = 0; a < changes.length; a++) {
    ObjectUpdate theObject = changes[a];
    String objName = theObject.getObj().getMoType().getName();
    // Must decide how to handle the value based on the name returned.
    // The only names returned are names found in the PropertySpec lists.
    // Get propertyName and value ...
}
```

Getting Specific Data

From time to time, you might need to get data that is relevant to a single item. In that case you can create a simple `ObjectSpec` including the `moRef` for the item of interest. The `PropertySpec` can then be set to obtain the properties you want, and you can use `RetrieveProperties` to get the data. Hopefully you can deduce `moRef` from a general examination of the properties, by searching for information from the `rootFolder`.

Identifying Virtual Disks for Backup and Restore

To back up a virtual machine, you first need to create a snapshot. Once the snapshot is created, you then need to identify the virtual disks associated with this snapshot. A virtual machine might have multiple snapshots associated with it. Each snapshot has a virtual “copy” of the virtual disks for the virtual machine. These copies are named with the base name of the disk, and a unique decimal number appended to the name. The format of the number is a hyphen character followed by a 6-digit zero-filled number. An example a disk copy name might be `mydisk-NNNNNN.vmdk` where `NNNNNN` would be some number like: `000032`.

The vSphere API identifies virtual disk files by prefixing the datastore name onto the file system pathname and the filename: `[storageN] myvmname/mydisk-NNNNNN.vmdk`. The name in square brackets corresponds to the short name of the datastore that contains this virtual disk, while the remainder of the path string represents the location relative to the root of this datastore.

To get the name and characteristics of a virtual disk file, you use the `PropertyCollector` to select the property: `config.hardware.device` from a `VirtualMachine` managed object. This returns an array of virtual devices associated with a `VirtualMachine` or `Snapshot`. You must scan this list of devices to extract the list of virtual disks. All that is necessary is to see if each `VirtualDevice` entry extends to `VirtualDisk`. When you find such an entry, examine the `BackingInfo` property. You must extend the type of the backing property to one of the following, or a `VirtualMachineSnapshot` managed object:

- `VirtualDiskFlatVer1BackingInfo`
- `VirtualDiskFlatVer2BackingInfo`
- `VirtualDiskRawDiskMappingVer1BackingInfo`
- `VirtualDiskSparseVer1BackingInfo`
- `VirtualDiskSparseVer2BackingInfo`

It is important to know which backing type is in use in order to be able to re-create the Virtual Disk. It is also important to know that you cannot snapshot a disk of type `VirtualDiskRawDiskMappingVer1BackingInfo`, and therefore you cannot back up this type of Virtual Disk.

The properties of interest are the backing `fileName` and the `VirtualDisk capacityInKB`. Additionally, when change tracking is in place, you should also save the `changeID`.

Creating a Snapshot

Before performing a backup operation, you must create a snapshot of the target virtual machine. Both full and incremental backup rely on the snapshot in vSphere.

With SAN transport on VMFS volumes, the virtual machine should not have any pre-existing snapshots, so that reporting of in-use disk sectors will work. For details see [About Changed Block Tracking](#).

As a best practice, you should search for and delete any pre-existing snapshots with the same name that you selected for the temporary snapshot. These snapshots are possibly remnants from failed backup attempts.

Within a specific snapshot, the names of virtual disk files (with extension `.vmdk`) can be modified with a zero-filled 6-digit decimal sequence number to ensure that the `.vmdk` files are uniquely named.

Depending on whether or not the current virtual machine had a pre-existing snapshot, the disk name for a snapshot could have this format: `<diskname>--<NNNNNN>.vmdk`. This unique name is no longer valid after the snapshot is destroyed, so any data for a snapshot disk should be stored in the backup program under its base disk name.

The following code sample shows how to create a snapshot on a specific virtual machine:

```
// At this point we assume the virtual machine is identified as ManagedObjectReference vmMoRef.
String SnapshotName = "Backup";
String SnapshotDescription = "Temporary Snapshot for Backup";
boolean memory_files = false;
boolean quiesce_filesystem = true;
ManagedObjectReference taskRef = serviceConnection.getService().CreateSnapshot_Task(vmMoRef,
    SnapshotName, SnapshotDescription, memory_files, quiesce_filesystem);
```

You can use the `taskRef` return value as a `moRef` to track progress of the snapshot operation. After successful completion, `taskRef.info.result` contains the `moRef` of the snapshot.

Backing Up a Virtual Disk

This section describes how to get data from the Virtual Disk after you have identified it. In order to access a virtual disk, you must use the `VixDiskLib`. The following code shows how to initialize the `VixDiskLib` and use it for accessing a virtual disk. All operations require a `VixDiskLib` connection to access virtual disk data. At the present time `VixDiskLib` is not implemented for the Java language, so this code is C++ language:

```
VixDiskLibConnectParams connectParams;
VixDiskLibConnection srcConnection;
connectParams.serverName = strdup("TargetServer");
connectParams.creds.uid.userName = strdup("root");
connectParams.creds.uid.password = strdup("yourPasswd");
connectParams.port = 902;
VixError vixError = VixDiskLib_Init(1, 0, &logFunc, &warnFunc, &panicFunc, libDir);
vixError = VixDiskLib_Connect(&connectParams, &srcConnection);
```

This next section of code shows how to open and read a specific virtual disk:

```
VixDiskLibHandle diskHandle;
vixError = VixDiskLib_Open(srcConnection, diskPath, flags, &diskHandle);
uint8 mybuffer[some_multiple_of_512];
vixError = VixDiskLib_Read(diskHandle, startSector, numSectors, &mybuffer);
// Also getting the disk metadata:
size_t requiredLength = 1;
char *buf = new char [1];
// This next operation fails, but updates "requiredLength" with the proper buffer size
vixError = VixDiskLib_GetMetadataKeys(diskHandle, buf, requiredLength, &requiredLength);
delete [] buf;
buf = new char[requiredLength]; // Create a large enough buffer
vixError = VixDiskLib_GetMetadataKeys(diskHandle, buf, requiredLength, NULL);
// And finally, close the diskHandle:
vixError = VixDiskLib_Close(diskHandle);
// And if you are completely done with the VixDiskLib
VixDiskLib_Disconnect(srcConnection);
VixDiskLib_Exit();
```

Deleting a Snapshot

When you are done performing a backup, you need to delete the temporary snapshot. You can get the `moRef` for the snapshot from `taskRef.info.result` as describe above for the create snapshot operation. The following Java code demonstrates how to delete the snapshot:

```
ManagedObjectReference removeSnapshotTask;
ManagedObjectReference snapshot; // Already initialized.
removeSnapshotTask = serviceConnection.getService().removeSnapshot_Task(snapshot, Boolean FALSE);
```

New Query Allocated Blocks Function

As of vSphere 6.7, developers can call `VixDiskLib_QueryAllocatedBlocks` to accelerate the backup process, especially with large virtual disks. By knowing which blocks are allocated, an application can avoid reading irrelevant sectors and thus reduce data transfer during backup.

Function Signatures

The `VixDiskLib_QueryAllocatedBlocks` function synchronously retrieves a list of allocated blocks. On an open VMDK, it queries for allocated blocks by chunks. A chunk is defined as a block of consecutive sectors. The calling program can specify chunk size to control granularity, along with starting sector and extent.

```
VixError
VixDiskLib_QueryAllocatedBlocks(VixDiskLibHandle diskHandle,
                               VixDiskLibSectorType startSector,
                               VixDiskLibSectorType numSectors,
                               VixDiskLibSectorType chunkSize,
                               VixDiskLibBlockList **blockList )
```

Parameters

- `diskHandle` [in] Handle to an open virtual disk.
- `startSector` [in] Absolute offset, possibly zero (0).
- `numSectors` [in] Number of sectors to query.
- `chunkSize` [in] Minimum number of sectors covered by a chunk containing data.
- `blockList` [out] Buffer containing a `VixDiskLibBlockList`.

Return: `VIX_OK` on success, otherwise a suitable VIX error code.

Backup programs must call the `VixDiskLib_FreeBlockList` function to deallocate the returned `blockList` when done with it.

```
VixError
VixDiskLib_FreeBlockList(VixDiskLibBlockList *blockList)
```

Parameters

- `blockList [out]` Buffer with above returned `VixDiskLibBlockList`.

Return: `VIX_OK` on success, otherwise a suitable VIX error code.

About Query Allocated Blocks

This function supplements the `QueryChangedDiskAreas` function, which is the vSphere API for changed block tracking (CBT). Backup software can start by calling `VixDiskLib_QueryAllocatedBlocks` to get a list of allocated blocks, instead of calling `QueryChangedDiskAreas` with special change ID ("*") to return only active portions of a virtual disk. Calling `QueryAllocatedBlocks` is easier, and its implementation is simpler. Consequently the special change ID ("*") is deprecated in this release. It had issues with pre-existing snapshots, and was slow when used with extremely large disks.

`Query allocated blocks` does not depend on CBT. You can enable CBT either before or after the call. Although new in vSphere 6.7, `QueryAllocatedBlocks` works against vSphere 6.5 and 6.0 as well.

`VixDiskLib_QueryAllocatedBlocks` can be used on object-oriented datastores such as vSAN and VVols (virtual volumes). It is especially helpful for backing up thin-provisioned disks. To skip copying non-allocated regions, programs call `QueryAllocatedBlocks` to get the list of allocated blocks returned in the final parameter. This works for large sparsely allocated virtual disks even when CBT is not enabled.

One limitation is that `VixDiskLib_QueryAllocatedBlocks` returns the whole VMDK for NFS, rather than just the allocated blocks as for VMFS, vSAN, and VVol datastores.

In file transport mode, `VixDiskLib_QueryAllocatedBlocks` depends on the disk library to support local VMDK files. In NBD(SSL) transport mode, an NFC message queries the bitmap of allocated sectors. In SAN and HotAdd transport modes, raw disk in the guest OS does not contain allocated sector information, so the function depends on the aforementioned NFC message to get a bitmap of allocated sectors.

Use Cases for Query Allocated Blocks

To accelerate the initial full backup of allocated disk:

- 1 Open the VMDK file.
- 2 Query allocated blocks.
- 3 Read and save the allocated blocks.
- 4 Close the VMDK file. Repeat steps for subsequent VMDK files.

For an incremental or differential backup:

- 1 Call `QueryChangedDiskAreas` with `changeId` of the epoch (point in time of last backup) to find all areas that have changed since the last backup. This is **A1**.
- 2 Use `VixDiskLib_QueryAllocatedBlocks` to find all valid data sectors. This is **A2**.
- 3 The intersection of the two sets ($A1 \cap A2$) yields the regions that have changed and are allocated. The backup application should save the data in these regions (the intersection).

- 4 The area $A1$ minus the intersection ($A1 - (A1 \cap A2)$) yields the regions that were changed but unmapped. The backup application can record those regions as zeroed without reading them.

This is highly useful when backing up an AUTO-UNMAP enabled VMDK. Since unmapped blocks can be recorded as "changed block" by CBT, without the `QueryAllocatedBlocks` call, those unmapped blocks get backed up unnecessarily. With the features together, as described in above, the real changed blocks (namely excluding unmapped) can be calculated.

Code Sample for Query Allocated Blocks

In the development kit, see the `vixDiskLibSample.cpp` program for its sample code related to `chunkSize`. The `DoGetAllocatedBlocks` routine calls the query allocated blocks function, after being requested by the `-getallocatedblocks` command line argument.

Changed Block Tracking on Virtual Disks

On ESXi hosts release 4.0 and later, virtual machines can keep track of disk sectors that have changed. This is called changed block tracking. Its method in the VMware vSphere API is `QueryChangedDiskAreas`, which takes the following parameters:

- `_this` – Managed object reference to the virtual machine.
- `snapshot` – Managed object reference to a Snapshot of the virtual machine.
- `deviceKey` – Virtual disk for which to compute the changes.
- `startOffset` – Byte offset where to start computing changes to virtual disk. The length of virtual disk sector(s) examined is returned in `DiskChangeInfo`.
- `changeId` – An identifier for the state of a virtual disk at a specific point in time. A new `ChangeId` results every time someone creates a snapshot. You should retain this value with the version of change data that you extract (using `QueryChangedDiskAreas`) from the snapshot's virtual disk.

When you back up a snapshot for the first time, `ChangeId` should be unset, or unsaved, indicating that a baseline (full) backup is required. If you have a saved `ChangeId`, it identifies the last time a backup was taken, and tells the changed block tracking logic to identify changes that have occurred since the time indicated by the saved `ChangeId`.

There are two ways to get this baseline backup:

- Directly save the entire contents of the virtual disk.
- Call the `VixDiskLib_QueryAllocatedBlocks` function, which returns the allocated portions of a virtual disk. Usually this substantially reduces the amount of data to save, especially for thin provisioned and sparse virtual disks.

To summarize, `changeID` is an identifier for a time in the past. It should be a `changeId` string saved at the time when a pre-backup snapshot was taken. If a previous `ChangeId` does exist, then

`QueryChangedDiskAreas` returns the disk sectors that changed since the new `ChangeId` was collected.

[Table 7-3](#) shows the algorithm.

Table 7-3. Use of Change ID for Changed Block Tracking

New Change ID	Old Change ID	Used for Query	Result
change 0	none	null	All sectors, use Query Allocated Sectors instead.
change 1	change 0	change 0	All sectors altered since change 0.

Enable Changed Block Tracking

This feature is disabled by default, because it reduces performance by a small but measurable amount. If you query the virtual machine configuration, you can determine if it is capable of changed block tracking. Use the property collector to retrieve the capability field from the `VirtualMachineManagedObject`. If the capability field contains the flag `changeTrackingSupported`, then you can proceed. The virtual machine version must be 7 or higher to support this. If the virtual machine version is lower than 7, upgrade the virtual hardware.

If supported, you enable changed block tracking using an abbreviated form of `VirtualMachineConfigSpec`, then use the `ReconfigVM_Task` method to reconfigure the virtual machine with changed block tracking:

```
VirtualMachineConfigSpec configSpec = new VirtualMachineConfigSpec();
configSpec.changeTrackingEnabled = new Boolean(true);
ManagedObjectReference taskMoRef =
    serviceConnection.getService().ReconfigVm_Task(targetVM_MoRef, configSpec);
```

Powered-on virtual machines must go through a stun-unstun cycle (triggered either by power on, migrate, resume after suspend, or snapshot create/delete/revert) before the virtual machine reconfiguration takes effect.

To enable changed block tracking with the vSphere Client:

- 1 Select the virtual machine and ensure that **Summary > VM Version** says “7” or higher compatibility.
- 2 In the Summary tab, click **Edit Settings > Options > Advanced > General**.
- 3 In the right side of the dialog box, click **Configuration Parameters...**
- 4 In the new dialog box, locate or create a row with name `ctkEnabled`, and set its value to `true` not `false`. See above concerning the stun-unstun cycle.

To enable changed block tracking and back up with the VMware vSphere API:

- 1 Query change tracking status of the virtual machine. If false, activate changed block tracking.

```
configSpec.changeTrackingEnabled = new Boolean(true);
```

- 2 Create a snapshot of the virtual machine. The snapshot operation causes a stun-unstun cycle.

```
CreateSnapshot_Task(VMmoRef, SnapshotName, Description, memory_files, quiesce_filesystem);
```

- 3 Starting from the snapshot’s `ConfigInfo`, work your way to the `BackingInfo` of all virtual disks in the snapshot. This gives you the change IDs for all the disks of the virtual machine.

- 4 Hold onto the change IDs and do a full backup of the snapshot, since this is the first time for backup.

```
VixDiskLib_Read(snapshotDiskHandle, startSector, numSectors, &buffer); /* C not Java */
```

- 5 Delete the snapshot when your backup has completed.

```
removeSnapshot_Task(SnapshotName, Boolean FALSE);
```

- 6 Next time you back up this virtual machine, create a snapshot and use `QueryChangedDiskAreas` with the change IDs from your previous backup to take advantage of changed block tracking.

```
changes = theVM.queryChangedDiskAreas(SnapshotMoRef, diskDeviceKey, startPosition, changeId);
```

Gathering Changed Block Information

Associated with changed block tracking is `changeId`, an identifier for versions of changed block data. Whenever a virtual machine snapshot is created, associated with that snapshot is a `changeId` that functions as a landmark to identify changes in virtual disk data. So it follows that when a snapshot is created for the purpose of creating an initial virtual disk backup, the `changeId` associated with that snapshot can be used to retrieve changes that have occurred since snapshot creation.

To obtain the `changeId` associated with any disk in a snapshot, you examine the “hardware” array from the snapshot. Any item in the devices table that is of type `vim.vm.device.VirtualDevice.VirtualDisk` encloses a class describing the “backing storage” (obtained using `getBacking`) that implements virtual disk. If backing storage is one of the following disk types, you can use the `changeId` property of the `BackingInfo` data object to obtain the `changeId`:

```
vim.vm.device.VirtualDevice.VirtualDiskFlatVer2BackingInfo
vim.vm.device.VirtualDevice.VirtualDiskSparseVer2BackingInfo
vim.vm.device.VirtualDevice.VirtualDiskRawDiskMappingVer1BackingInfo
vim.vm.device.VirtualDevice.VirtualDiskRawDiskVer2BackingInfo
```

Information returned by the `QueryChangedDiskAreas` method is a `DiskChangeInfo` data object containing an array of `DiskChangeInfo.DiskChangeExtent` items that enumerate the start offset and length of various disk areas that changed, and the length and start offset of the entire disk area covered by `DiskChangeInfo`.

When using `QueryChangedDiskAreas` to gather information about snapshots, enable change tracking before taking a snapshot. Attempts to collect information about changes that occurred before change tracking was enabled result in a `FileFault` error. Enabling change tracking provides the additional benefit of saving space because it enables backup of only information that has changed. If change tracking is not enabled, the entire virtual machine must be backed up each time, rather than incrementally.

Changed block tracking is supported whenever the I/O operations are processed by the ESXi storage stack:

- For a virtual disk stored on VMFS, no matter what backs the VMFS volume (SAN or local disk).
- For a virtual disk stored on NFS (though thick vs thin might be an issue).

- For an RDM in virtual compatibility mode.

When I/O operations are not processed by the ESXi storage stack, changed block tracking is not usable:

- For an RDM in physical compatibility mode.
- A disk that is accessed directly from inside a VM. For example if you are running an iSCSI initiator within the virtual machine to access an iSCSI LUN from inside the VM, vSphere cannot track it.

If the guest actually wrote to each block of a virtual disk (long format or secure erase), or if the virtual disk is thick and eager zeroed, or cloned thick disk, then the query may report the entire disk as being in use.

To find change information, you can use the managed object browser at <http://<ESXhost>/mob> to follow path **content > rootFolder > datacenter > datastore > vm > snapshot > config > hardware > virtualDisk > backing**. Changed block tracking information (changeId) appears in the BackingInfo.

The following C++ code sample assumes that, in the past, you obtained a complete copy of the virtual disk, and at the time when the changeId associated with the snapshot was collected, you stored it for use at a later time, which is now. A new snapshot has been created, and the appropriate moRef is available:

```
String changeId;      // Already initialized: changeId, snapshotMoRef, theVM
ManagedObjectReference snapshotMoRef;
ManagedObjectReference theVM;
int diskDeviceKey;   // Identifies the virtual disk.
VirtualMachine.DiskChangeInfo changes;
long startPosition = 0;
do {
    changes = theVM.queryChangedDiskAreas(snapshotMoRef, diskDeviceKey, startPosition, changeId);
    for (int i = 0; i < changes.changedArea.length; i++) {
        long length = changes.changedArea[i].length;
        long offset = changes.changedArea[i].startOffset;
        //
        // Go get and save disk data here
    }
    startPosition = changes.startOffset + changes.length;
} while (startPosition < diskCapacity);
```

In the above code, QueryChangedDiskAreas is called repeatedly, as position moves through the virtual disk. This is because the number of entries in the ChangedDiskArea array could occupy a large amount of memory for describing changes to a large virtual disk. Some disk areas may have no changes for a given changeId.

The changeId (changed block ID) contains a sequence number in the form <UUID>/<nnn>. If <UUID> changes, it indicates that tracking information has become invalid, necessitating a full backup. Otherwise incremental backups can continue in the usual pattern.

Troubleshooting

If you reconfigure a virtual machine to set `changeTrackingEnabled`, but the property remains false, check that you have queried the virtual machine status with `VirtualMachine->config()` after reconfiguration with `VirtualMachine->reconfigure()` and not before. Also make sure that virtual machine compatibility is hardware version 7 or higher, and that it has undergone a `stun-unstun` cycle since reconfiguration.

Limitations on Changed Block Tracking

Changed block tracking does not work if the virtual hardware version is 6 or earlier, in physical compatibility RDM mode, or when the virtual disk is attached to a shared virtual SCSI bus. ESXi 3.5 supported only up to virtual hardware version 4.

Changed block tracking can be enabled on virtual machines that have disks like these, but when queried for their change ID, these disks always return an empty string. So if you have a virtual machine with a regular system disk and a pass-through RDM as a data disk, you can track changes only on the system disk.

Checking for Namespace

You can avoid using the `queryChangedDiskAreas` API on ESXi 3.5 based storage by parsing XML files for the namespace. For prepackaged methods that do this, see these SDK code samples:

```
Axis/java/com/vmware/samples/version/displaynewpropertieshost/DisplayNewPropertiesHostV25.java
Axis/java/com/vmware/samples/version/getvirtualdiskfiles/GetVirtualDiskFilesV25.java
DotNet/cs/DisplayNewProperties/DisplayNewPropertiesV25.cs
DotNet/cs/GetVirtualDiskFiles/GetVirtualDiskFilesV25.cs
```

Low Level Restore Procedures

The following sections describe how to recover virtual machines and restore virtual disk data.

- [Restoring a Virtual Machine and Disk](#)
- [Restore Incremental Backup Data](#)

Restoring a Virtual Machine and Disk

You cannot get write access to a virtual disk that is in active use. For a full restore, you first must ensure that the virtual disk is not in use by halting the parent virtual machine, then performing the “power off” sequence. The following code sample demonstrates how to “power off” a Virtual Machine:

```
// At this point we assume that you have a ManagedObjectReference to the VM - vmMoRef.
// Power on would need a ManagedObjectReference to the host running the VM - hostMoRef.
ManagedObjectReference taskRef = serviceConnection.powerOffVm(vmMoRef);
```

With SAN transport mode, you must create a snapshot of the virtual machine before virtual disk restore. See [Creating a Snapshot](#). If at restore time the virtual machine had a pre-existing snapshot, you must delete it, otherwise SAN mode restore will fail. For other transport modes, the restore snapshot is optional.

With a VVol datastore, the restore snapshot is forbidden when restoring to the parent (backing disk). A null MoRef is allowed as of vSphere 6.0 to minimize code changes when applications restore to a VVol datastore. To get the unique ID of a VVol object in the MOB (managed object browser) click VirtualMachine > Config > Hardware > Device (VirtualDisk) > Backing.

[Table 7-4](#) summarizes the snapshot requirements.

Table 7-4. Summary of restore snapshot requirements

	NBDSSL	HotAdd	SAN
Non-VVol datastore	A snapshot is optional. If a snapshot is used, writing to either the leaf disk or the parent disk is supported. If writing to the parent disk, the snapshot must be reverted and then deleted.		A snapshot is required. Writing to the leaf disk is not supported, and writes must only go to the base disk. The snapshot must be reverted and then deleted.
VVol datastore	A snapshot is optional. If a snapshot is used, writing must be to the leaf disk only.		Not applicable, because SAN transport is not supported on VVol datastores.

In this phase you use VixDiskLib to reload contents of the Virtual Disk, so the following code is C++ not Java:

```
// At this point we assume that you already have a VixDiskLib connection to the server machine.
uint8 mybuffer[some_multiple_of_512];
int mylocalfile = open("localfile", openflags); // Contains backup copy of virtual disk.
read(mylocalfile, mybuffer, sizeof mybuffer);
vixError = VixDiskLib_Open(srcConnection, path, flags, &diskHandle);
VixDiskLib_Write(diskHandle, startsector, (sizeof mybuffer) / 512, mybuffer);
```

With SAN transport mode, you must revert-to and delete the snapshot. If you forget the snapshot revert, snapshot delete will fail due to CID mismatch, so the virtual machine cannot be powered on. If you forget the snapshot delete, the extraneous snapshot will cause restore problems for subsequent backups.

Creating a Virtual Machine

This section shows how to create a VirtualMachine object, which is complicated but necessary so you can restore data into it. Before creating this object, you must create a VirtualMachineConfigSpec describing the virtual machine and all of its supporting virtual devices. Almost all the required information is available from the virtual machine property config.hardware.device, which is a table containing the device configuration information. The relationships between devices are described by the value key, which is a unique identifier for the device. In turn, each device has a controllerKey, which is the key identifier of the controller where the device is connected. Use negative integers as temporary key values

in the `VirtualMachineConfigSpec` to guarantee that temporary key numbers do not conflict with real key numbers when they are assigned by the server. When associating virtual devices with default devices, the `controllerKey` property should be reset with the `key` property of the controller. Below are the settings for a sample `VirtualMachineConfigSpec` used to create a virtual machine.

```
// beginning of VirtualMachineConfigSpec, ends several pages later
{
    dynamicType = <unset>,
    changeVersion = <unset>,
//This is the display name of the VM
    name = "My New VM",
    version = "vmx-04",
    uuid = <unset>,
    instanceUuid = <unset>,
    npivWorldWideNameType = <unset>,
    npivDesiredNodeWwns = <unset>,
    npivDesiredPortWwns = <unset>,
    npivTemporaryDisabled = <unset>,
    npivOnNonRdmDisks = <unset>,
    npivWorldWideNameOp = <unset>,
    locationId = <unset>,
// This is advisory, the disk determines the O/S
    guestId = "winNetStandardGuest",
    alternateGuestName = "Microsoft Windows Server 2008, Enterprise Edition",
    annotation = <unset>,
    files = (vim.vm.FileInfo) {
        dynamicType = <unset>,
        vmPathName = "[plat004-local]",
        snapshotDirectory = "[plat004-local]",
        suspendDirectory = <unset>,
        logDirectory = <unset>,
    },
    tools = (vim.vm.ToolsConfigInfo) {
        dynamicType = <unset>,
        toolsVersion = <unset>,
        afterPowerOn = true,
        afterResume = true,
        beforeGuestStandby = true,
        beforeGuestShutdown = true,
        beforeGuestReboot = true,
        toolsUpgradePolicy = <unset>,
        pendingCustomization = <unset>,
        syncTimeWithHost = <unset>,
    },
    flags = (vim.vm.FlagInfo) {
        dynamicType = <unset>,
        disableAcceleration = <unset>,
        enableLogging = <unset>,
        useToe = <unset>,
        runWithDebugInfo = <unset>,
        monitorType = <unset>,
        htSharing = <unset>,
        snapshotDisabled = <unset>,
        snapshotLocked = <unset>,
    },
}
```

```

    diskUuidEnabled = <unset>,
    virtualMmuUsage = <unset>,
    snapshotPowerOffBehavior = "powerOff",
    recordReplayEnabled = <unset>,
},
consolePreferences = (vim.vm.ConsolePreferences) null,
powerOpInfo = (vim.vm.DefaultPowerOpInfo) {
    dynamicType = <unset>,
    powerOffType = "preset",
    suspendType = "preset",
    resetType = "preset",
    defaultPowerOffType = <unset>,
    defaultSuspendType = <unset>,
    defaultResetType = <unset>,
    standbyAction = "powerOnSuspend",
},
// the number of CPUs
numCPUs = 1,
// the number of memory megabytes
memoryMB = 256,
memoryHotAddEnabled = <unset>,
cpuHotAddEnabled = <unset>,
cpuHotRemoveEnabled = <unset>,
deviceChange = (vim.vm.device.VirtualDeviceSpec) [
    (vim.vm.device.VirtualDeviceSpec) {
        dynamicType = <unset>,
        operation = "add",
        fileOperation = <unset>,
        // CDRROM
        device = (vim.vm.device.VirtualCdrom) {
            dynamicType = <unset>,
            // key number of CDRROM
            key = -42,
            deviceInfo = (vim.Description) null,
            backing = (vim.vm.device.VirtualCdrom.RemotePassthroughBackingInfo) {
                dynamicType = <unset>,
                deviceName = "",
                useAutoDetect = <unset>,
                exclusive = false,
            },
            connectable = (vim.vm.device.VirtualDevice.ConnectInfo) {
                dynamicType = <unset>,
                startConnected = false,
                allowGuestControl = true,
                connected = false,
            },
            // connects to this controller
            controllerKey = 200,
            unitNumber = 0,
        },
    },
},
(vim.vm.device.VirtualDeviceSpec) {
    dynamicType = <unset>,
    operation = "add",
    fileOperation = <unset>,

```

```

    // SCSI controller
    device = (vim.vm.device.VirtualLsiLogicController) {
        dynamicType = <unset>,
// key number of SCSI controller
        key = -44,
        deviceInfo = (vim.Description) null,
        backing = (vim.vm.device.VirtualDevice.BackingInfo) null,
        connectable = (vim.vm.device.VirtualDevice.ConnectInfo) null,
        controllerKey = <unset>,
        unitNumber = <unset>,
        busNumber = 0,
        hotAddRemove = <unset>,
        sharedBus = "noSharing",
        scsiCtlrUnitNumber = <unset>,
    },
},
(vim.vm.device.VirtualDeviceSpec) {
    dynamicType = <unset>,
    operation = "add",
    fileOperation = <unset>,
// Network controller
    device = (vim.vm.device.VirtualPCNet32) {
        dynamicType = <unset>,
// key number of Network controller
        key = -48,
        deviceInfo = (vim.Description) null,
        backing = (vim.vm.device.VirtualEthernetCard.NetworkBackingInfo) {
            dynamicType = <unset>,
            deviceName = "Virtual Machine Network",
            useAutoDetect = <unset>,
            network = <unset>,
            inPassthroughMode = <unset>,
        },
        connectable = (vim.vm.device.VirtualDevice.ConnectInfo) {
            dynamicType = <unset>,
            startConnected = true,
            allowGuestControl = true,
            connected = true,
        },
        controllerKey = <unset>,
        unitNumber = <unset>,
        addressType = "generated",
        macAddress = <unset>,
        wakeOnLanEnabled = true,
    },
},
(vim.vm.device.VirtualDeviceSpec) {
    dynamicType = <unset>,
    operation = "add",
    fileOperation = "create",
// SCSI disk one
    device = (vim.vm.device.VirtualDisk) {
        dynamicType = <unset>,
// key number for SCSI disk one
        key = -1000000,

```

```

    deviceInfo = (vim.Description) null,
    backing = (vim.vm.device.VirtualDisk.FlatVer2BackingInfo) {
        dynamicType = <unset>,
        fileName = "",
        datastore = <unset>,
        diskMode = "persistent",
        split = false,
        writeThrough = false,
        thinProvisioned = <unset>,
        eagerlyScrub = <unset>,
        uuid = <unset>,
        contentId = <unset>,
        changeId = <unset>,
        parent = (vim.vm.device.VirtualDisk.FlatVer2BackingInfo) null,
    },
    connectable = (vim.vm.device.VirtualDevice.ConnectInfo) {
        dynamicType = <unset>,
        startConnected = true,
        allowGuestControl = false,
        connected = true,
    },
    // controller for SCSI disk one
    controllerKey = -44,
    unitNumber = 0,
    // size in MB SCSI disk one
    capacityInKB = 524288,
    committedSpace = <unset>,
    shares = (vim.SharesInfo) null,
},
(vim.vm.device.VirtualDeviceSpec) {
    dynamicType = <unset>,
    operation = "add",
    fileOperation = "create",
    // SCSI disk two
    device = (vim.vm.device.VirtualDisk) {
        dynamicType = <unset>,
// key number of SCSI disk two
        key = -100,
        deviceInfo = (vim.Description) null,
        backing = (vim.vm.device.VirtualDisk.FlatVer2BackingInfo) {
            dynamicType = <unset>,
            fileName = "",
            datastore = <unset>,
            diskMode = "persistent",
            split = false,
            writeThrough = false,
            thinProvisioned = <unset>,
            eagerlyScrub = <unset>,
            uuid = <unset>,
            contentId = <unset>,
            changeId = <unset>,
            parent = (vim.vm.device.VirtualDisk.FlatVer2BackingInfo) null,
        },
        connectable = (vim.vm.device.VirtualDevice.ConnectInfo) {

```

```

        dynamicType = <unset>,
        startConnected = true,
        allowGuestControl = false,
        connected = true,
    },
    // controller for SCSI disk two
    controllerKey = -44,
    unitNumber = 1,
    // size in MB SCSI disk two
    capacityInKB = 131072,
    committedSpace = <unset>,
    shares = (vim.SharesInfo) null,
},
}
},
cpuAllocation = (vim.ResourceAllocationInfo) {
    dynamicType = <unset>,
    reservation = 0,
    expandableReservation = <unset>,
    limit = <unset>,
    shares = (vim.SharesInfo) {
        dynamicType = <unset>,
        shares = 100,
        level = "normal",
    },
    overheadLimit = <unset>,
},
memoryAllocation = (vim.ResourceAllocationInfo) {
    dynamicType = <unset>,
    reservation = 0,
    expandableReservation = <unset>,
    limit = <unset>,
    shares = (vim.SharesInfo) {
        dynamicType = <unset>,
        shares = 100,
        level = "normal",
    },
    overheadLimit = <unset>,
},
cpuAffinity = (vim.vm.AffinityInfo) null,
memoryAffinity = (vim.vm.AffinityInfo) null,
networkShaper = (vim.vm.NetworkShaperInfo) null,
swapPlacement = <unset>,
swapDirectory = <unset>,
preserveSwapOnPowerOff = <unset>,
bootOptions = (vim.vm.BootOptions) null,
appliance = (vim.vService.ConfigSpec) null,
ftInfo = (vim.vm.FaultToleranceConfigInfo) null,
applianceConfigRemoved = <unset>,
vAssertsEnabled = <unset>,
changeTrackingEnabled = <unset>,
}
// end of VirtualMachineConfigSpec

```

The information above is quite complex, but much of the input consists of defaulted values that are assigned by the system. The remainder of the supplied information can be extracted from the output of the `config.hardware.device` table returned from `PropertyCollector`. Borrowing heavily from an SDK code example, the following code sets up the configuration specification:

```
// Duplicate virtual machine configuration
VirtualMachineConfigSpec configSpec = new VirtualMachineConfigSpec();
// Set the VM values
configSpec.setName("My New VM");
configSpec.setVersion("vmx-04");
configSpec.setGuestId("winNetStandardGuest");
configSpec.setNumCPUs(1);
configSpec.setMemoryMB(256);
// Set up file storage info
VirtualMachineFileInfo vmfi = new VirtualMachineFileInfo();
vmfi.setVmPathName("[plat004-local]");
configSpec.setFiles(vmfi);
vmfi.setSnapshotDirectory("[plat004-local]");
// Set up tools config info
ToolsConfigInfo tools = new ToolsConfigInfo();
configSpec.setTools(tools);
tools.setAfterPowerOn(new Boolean(true));
tools.setAfterResume(new Boolean(true));
tools.setBeforeGuestStandby(new Boolean(true));
tools.setBeforeGuestShutdown(new Boolean(true));
tools.setBeforeGuestReboot(new Boolean(true));
// Set flags
VirtualMachineFlagInfo flags = new VirtualMachineFlagInfo();
configSpec.setFlags(flags);
flags.setSnapshotPowerOffBehavior("powerOff");
// Set power op info
VirtualMachineDefaultPowerOpInfo powerInfo = new VirtualMachineDefaultPowerOpInfo();
configSpec.setPowerOpInfo(powerInfo);
powerInfo.setPowerOffType("preset");
powerInfo.setSuspendType("preset");
powerInfo.setResetType("preset");
powerInfo.setStandbyAction("powerOnSuspend");
// Now add in the devices
VirtualDeviceConfigSpec[] deviceConfigSpec = new VirtualDeviceConfigSpec [5];
configSpec.setDeviceChange(deviceConfigSpec);
// Formulate the CDROM
deviceConfigSpec[0].setOperation(VirtualDeviceConfigSpecOperation.add);
VirtualCdrom cdrom = new VirtualCdrom();
VirtualCdromIsoBackingInfo cdDeviceBacking = new VirtualCdromRemotePassthroughBackingInfo();
cdDeviceBacking.setDatastore(datastoreRef);
cdrom.setBacking(cdDeviceBacking);
cdrom.setKey(-42);
cdrom.setControllerKey(new Integer(-200)); // Older Java required type for optional properties
cdrom.setUnitNumber(new Integer(0));
deviceConfigSpec[0].setDevice(cdrom);
// Formulate the SCSI controller
deviceConfigSpec[1].setOperation(VirtualDeviceConfigSpecOperation.add);
VirtualLsiLogicController scsiCtrl = new VirtualLsiLogicController();
scsiCtrl.setBusNumber(0);
```

```

deviceConfigSpec[1].setDevice(scsiCtrl);
scsiCtrl.setKey(-44);
scsiCtrl.setSharedBus(VirtualSCSISharing.noSharing);
// Formulate SCSI disk one
deviceConfigSpec[2].setFileOperation(VirtualDeviceConfigSpecFileOperation.create);
deviceConfigSpec[2].setOperation(VirtualDeviceConfigSpecOperation.add);
VirtualDisk disk = new VirtualDisk();
VirtualDiskFlatVer2BackingInfo diskfileBacking = new VirtualDiskFlatVer2BackingInfo();
diskfileBacking.setDatastore(datastoreRef);
diskfileBacking.setFileName(volumeName);
diskfileBacking.setDiskMode("persistent");
diskfileBacking.setSplit(new Boolean(false));
diskfileBacking.setWriteThrough(new Boolean(false));
disk.setKey(-1000000);
disk.setControllerKey(new Integer(-44));
disk.setUnitNumber(new Integer(0));
disk.setBacking(diskfileBacking);
disk.setCapacityInKB(524288);
deviceConfigSpec[2].setDevice(disk);
// Formulate SCSI disk two
deviceConfigSpec[3].setFileOperation(VirtualDeviceConfigSpecFileOperation.create);
deviceConfigSpec[3].setOperation(VirtualDeviceConfigSpecOperation.add);
VirtualDisk disk2 = new VirtualDisk();
VirtualDiskFlatVer2BackingInfo diskfileBacking2 = new VirtualDiskFlatVer2BackingInfo();
diskfileBacking2.setDatastore(datastoreRef);
diskfileBacking2.setFileName(volumeName);
diskfileBacking2.setDiskMode("persistent");
diskfileBacking2.setSplit(new Boolean(false));
diskfileBacking2.setWriteThrough(new Boolean(false));
disk2.setKey(-100);
disk2.setControllerKey(new Integer(-44));
disk2.setUnitNumber(new Integer(1));
disk2.setBacking(diskfileBacking2);
disk2.setCapacityInKB(131072);
deviceConfigSpec[3].setDevice(disk2);
// Finally, formulate the NIC
deviceConfigSpec[4].setOperation(VirtualDeviceConfigSpecOperation.add);
com.VMware.vim.VirtualEthernetCard nic = new VirtualPCNet32();
VirtualEthernetCardNetworkBackingInfo nicBacking = new VirtualEthernetCardNetworkBackingInfo();
nicBacking.setNetwork(networkRef);
nicBacking.setDeviceName(networkName);
nic.setAddressType("generated");
nic.setBacking(nicBacking);
nic.setKey(-48);
deviceConfigSpec[4].setDevice(nic);
// Now that it is all put together, create the virtual machine.
// Note that folderMo, resourcePool, and hostMo, are moRefs to
// the Folder, ResourcePool, and Host where the VM is to be created.
ManagedObjectReference taskMoRef =
    serviceConnection.getService().createVM_Task(folderMo, configSpec, resourcePool, hostMo);

```

Using the VirtualMachineConfigInfo

A backup application can also use information contained in a `VirtualMachineConfigInfo`. If at backup time you preserve all the `VirtualMachineConfigInfo` details that describe the virtual machine, you can transfer much of this information into a `VirtualMachineConfigSpec` to create a virtual machine at restore time. However, some of the information in `VirtualMachineConfigInfo` is not needed, and if used in the Spec, virtual machine creation can fail. For example, a `VirtualMachineConfigSpec` that contains information about so called “Default Devices” usually fails. The list of default devices includes:

```
vim.vm.device.VirtualIDEController
vim.vm.device.VirtualPS2Controller
vim.vm.device.VirtualPCIController
vim.vm.device.VirtualSIOController
vim.vm.device.VirtualKeyboard
vim.vm.device.VirtualVMCIDevice
vim.vm.device.VirtualPointingDevice
```

However, other controllers and devices must be explicitly included in the `VirtualMachineConfigSpec`.

Some information about devices is unneeded and can cause problems if supplied. Each controller device has its `vim.vm.device.VirtualController.device` field, which is an array of devices that report to the controller. The server rebuilds this list when a virtual machine is created, using the (negative) device key numbers supplied as a guide. The relationship between controller and device must be preserved using negative key numbers in the same relationship as in the hardware array of `VirtualMachineConfigInfo`.

The parent property for virtual disk backing information must be set to null. In the sample code for creating a virtual machine, find `vim.vm.device.VirtualDisk.FlatVer2BackingInfo` under SCSI disk one and SCSI disk two. The null setting is required because the pre-backup snapshot causes the parent property to be populated with a reference to the base disk.

One other configuration needs substitution. `VirtualMachineConfigInfo` contains the `cpuFeatureMask`, field, which is an array of `HostCpuIdInfo`. The array entries must be converted to `ArrayUpdateSpec` entries containing the `VirtualMachineCpuIdInfoSpec` along with the “operation” field, which must contain the value `ArrayUpdateOperation::add`. The `VirtualMachineCpuIdInfoSpec` also contains a `HostCpuIdInfo` array that you can copy from the `cpuFeatureMask` array in `VirtualMachineConfigInfo`. These items are not reflected in the sample code. Everything else can be copied intact from `VirtualMachineConfigInfo` data.

To summarize: when creating a virtual machine in which to restore virtual disk:

- Exclude default devices, and `VirtualController.device`, from the `VirtualMachineConfigSpec`.
- Set the parent virtual disk backing information (`VirtualDisk.FlatVer2BackingInfo`) to null.
- Convert `HostCpuIdInfo` array entries to `ArrayUpdateSpec`, insert `ArrayUpdateOperation::add`, and copy the `HostCpuIdInfo` array from `cpuFeatureMask` into `VirtualMachineConfigInfo`.

Editing or Deleting a Device

If backup clients want to edit or delete a device, they must use the server-provided key when referring to an existing device. For the definition of key, see [Creating a Virtual Machine](#). For example, see the `key` and `controllerKey` below comments in the source code under CDRROM. The `key` uniquely identifies a device, while the `controllerKey` uniquely identifies the controller where it is connected.

Restoring Virtual Disk Data

As in the section [Low Level Restore Procedures](#), `VixDiskLib` functions provide interfaces for writing the data to virtual disk, either locally or remotely.

Raw Device Mapping (RDM) Disks

To create an RDM disk using `CreateVM_Task`, use a LUN that is not occupied and thus is still available. Developers sometimes use the same LUN `uuid` that is available in the `configInfo` object, which can cause errors because the LUN `uuid` is datastore specific.

Call `QueryConfigTarget` to fetch the `ConfigTarget.ScsiDisk.Disk.CanonicalName` property, set in `VirtualDiskRawDiskMappingVer1BackInfo.deviceName`. Also call `QueryConfigTarget` to fetch `ConfigTarget.ScsiDisk.Disk.uuid`, set in `VirtualDiskRawDiskMappingVer1BackInfo.lunUuid`. When creating the virtual machine, avoid host-specific properties of `configInfo`, which should be set according to host configuration where the virtual machine is restored.

Restore Incremental Backup Data

At some point you might need to restore a virtual disk from the backup data that you gathered as described in [Changed Block Tracking on Virtual Disks](#). The essential procedure is as follows:

Procedure

- 1 Power off the virtual machine, if powered on.
- 2 Using `VirtualMachineConfigInfo` that corresponds to the last known good state of the guest operating system, re-create the virtual machine as described in [Using the VirtualMachineConfigInfo](#).
- 3 Completely reload the base virtual disk using the full backup that started the most recent series of incremental backups.
- 4 Create a snapshot. This is mandatory for SAN mode restore.
A restore snapshot is forbidden when restoring to the parent (backing) disk on a VVol datastore.
- 5 For SAN mode restore, disable changed block tracking. SAN writes are not possible with it enabled

- 6 Sequentially restore the incremental backup data. You can do this either forwards or backwards. If you work forwards, the restore might write some sectors more than once. If you work backwards, you must keep track of which sectors were restored so as to avoid restoring them again from older data.
 - a From your backup records, get the change ID of the incremental backup to be restored. Your software must also store the changed-block information, so it knows which sectors of virtual disk to restore. Once you start restoring virtual disk, the change tracking mechanism will misreport.
 - b Restore only changed areas to the virtual disks referred to by the snapshot. This ensures that you do not write the data to the redo log created by the snapshot. When restoring a thin provisioned (sparse) disk, avoid writing zeroes to the unallocated blocks.
 - c Repeat steps a and b as necessary by applying incremental backup data sets in order.
- 7 If applicable (SAN mode) revert to the base virtual disk, thus eliminating the snapshot.

Restore with Direct Connection to ESXi Host

Sometimes you must restore a virtual machine directly to an ESXi host, for example in disaster recovery when vCenter Server runs on ESXi as a virtual machine. A new vSphere 5 feature tries to prevent this if the ESXi host is managed by vCenter. To circumvent this and restore the virtual machine, you must first disassociate the host from vCenter. In earlier releases, vCenter management had less state but was revocable only from vCenter.

Procedure

- 1 Using the vSphere Client, connect directly to the ESXi 5.0 or later host.
- 2 In the Inventory left-hand panel, select the host. In the right-hand panel, click Summary.
- 3 In the box titled Host Management, click **Disassociate host from vCenter Server**. You do not need to put the host in Maintenance Mode.
- 4 After the vCenter Server has been restored and is back in service, use it to reacquire the host.

Currently there is no API to disassociate a host from vCenter Server.

Tips and Best Practices

This section discusses the various advanced transport mechanisms, and other backup issues.

VDDK 5.0 contained two new VixDiskLib calls (`PrepareForAccess` and `EndAccess`) to disable and enable Storage vMotion during backup. This prevents stale disk images from being left behind if a virtual machine has its storage moved while a backup is taking place. VMware strongly recommends use of these calls.

When an ESXi host is managed by vCenter Server, vSphere API calls cannot contact the host directly: they must go through vCenter. If necessary, especially during disaster recovery, the administrator must disassociate the ESXi host from vCenter Server before the host can be contacted directly.

Advanced transports allow programs to transfer data in the most efficient manner. SAN transport is available only when the physical-machine host has SAN access. HotAdd works for the appliance model, where backup is done from inside virtual machines. HotAdd requires the virtual machine datastore to be accessible from the backup appliance. NBDSSL is a secure fallback when over-the-network backup is your only choice.

SAN transport is supported only on physical machines, and HotAdd transport is supported only on virtual machines. SAN requires a physical proxy to share a LUN with the ESXi host where a datastore resides, enabling direct access to raw data, and bypassing the host altogether for I/O operations. HotAdd involves attaching a virtual disk to the backup proxy just like attaching the disk to a virtual machine.

Best Practices for SAN Transport

For array-based storage, SAN transport is often the best performing choice for backups when running on a physical proxy. It is disabled inside virtual machines, so use SCSI HotAdd instead on a virtual proxy.

SAN transport is not always the best choice for restores. It offers the best performance on thick disks, but the worst performance on thin disks, because of round trips through two disk manager APIs, `AllocateBlock` and `ClearLazyZero`. For thin disk restore, NBDSSL is usually faster. Changed Block Tracking (CBT) must be disabled for SAN restores. SAN transport does not support writing to redo logs (child disks including linked clones and snapshots), only to base disks. SAN transport is not supported on VVol datastores.

Before vSphere 5.5, when writing to SAN during restore, disk size had to be a multiple of the underlying VMFS block size, otherwise the write to the last fraction of a disk would fail. This was fixed in the ESXi 5.5 release.

Programs that open a local virtual disk in SAN mode might be able to read (if the disk is empty) but writing will throw an error. Even if programs call `VixDiskLib_ConnectEx()` with `NULL` parameter to accept the default transport mode, SAN is selected as the preferred mode if SAN storage is connected to the ESXi host. `VixDiskLib` should, but does not, check SAN accessibility on open. With local disk, programs must explicitly request NBDSSL mode.

For a Windows Server 2008 and later proxy, set SAN policy to `onlineAll`. Set SAN disk to read-only except for restore. You can use the `diskpart` utility to clear the read-only flag. SAN policy varies by Windows Server 2008 edition. For Enterprise and Datacenter editions, the default Windows SAN policy is `offline`, which is unnecessary when vSphere mediates SAN storage.

For SAN transport, one major factor impacting performance is that the read buffer should be aligned with the sector size, currently 512. You can specify three parameters for `VixDiskLib_Read`: start sector, number of sectors to read, and the buffer to hold data. The proper read buffer size can be allocated using, for example, `_aligned_malloc` on Windows or `posix_memalign` on Linux. SAN mode performs best with about six concurrent streams per ESXi host; more than six streams usually results in slower total throughput.

Best Practices for HotAdd Transport

Deploy the proxy on VMFS-6 or VMFS-5 volumes, so that the proxy can back up very large virtual disks. HotAdd is a SCSI feature and does not work for IDE disks. The paravirtual SCSI controller (PVSCSI) is the recommended default for HotAdd, but other controller types work too.

A redo log is created for HotAdded disks, on the same datastore as the base disks. Do not remove the target virtual machine (the one being backed up) while HotAdded disk is still attached. If removed, HotAdd fails to properly clean up redo logs so virtual disks must be removed manually from the backup appliance. Also, do not remove the snapshot until after cleanup. Removing it could result in an unconsolidated redo log.

Removing all disks on a controller with the vSphere Client also removes the controller. You might want to include some checks in your code to detect this in your appliance, and reconfigure to add controllers back in.

HotAdded disks should be released with `VixDiskLib_Cleanup()` before snapshot delete. Cleanup might cause improper removal of the change tracking (ctk) file. You can fix it by power cycling the virtual machine.

Virtual disk created on Windows by HotAdd backup or restore may have a different disk signature than the original virtual disk. The workaround is to reread or rewrite the first disk sector in NBDSSL mode. Customers running a Windows Server 2008 or later proxy should make sure Windows automount is disabled.

The HotAdd implementation assumes that proxy and target VMs are on the same datastore and accessible from the same connection, that is, the same vCenter Server. This is so VADP can obtain a list of all disks on the target VM from a connection. In vCloud environments where two vCenter Servers share a single datastore, causing VADP to make two connections, there is no mechanism for informing one connection of the disks available on the other connection. VMware needs to redesign HotAdd to support multiple connections.

For unbuffered HotAdd restore, VMware recommends that programmers set the VDDK flag `VIXDISKLIB_FLAG_OPEN_UNBUFFERED` when opening virtual disks before performing a restore with HotAdd transport. In vSphere 6.7 releases and later, programs must allocate a data buffer whose memory address is sector size aligned when setting this flag. Programmers may refer to `posix_memalign` on Linux or `_aligned_malloc` on Windows. Buffer address alignment to sector size is recommended for older VDDK releases as well.

Best Practices for NBDSSL Transport

Various versions of ESXi have different defaults for timeouts. Before ESXi 5.0 there were no default network file copy (NFC) timeouts. Default NFC timeout values may change in future releases.

VMware recommends that you specify default NFC timeouts in the VixDiskLib configuration file. If you do not specify a timeout, older versions of ESXi hold the corresponding disk open indefinitely, until `vpva` or `hostd` is restarted. However if you do specify a timeout, you might need to perform some “keepalive” operation to prevent the disk from being closed on the server side. Reading block 0 periodically is a good keepalive operation. As a starting point, recommended settings are three minutes for Accept and Request, one minute for Read, ten minutes for Write, and no timeouts (0) for `nfcFssrvr` and `nfcFssrvrWrite`.

The best way to improve NBDSSL performance is to use a relatively small buffer size (2MB or less) to improve concurrency. Also as of vSphere 6.7, asynchronous I/O is available.

General Backup and Restore

With SSL certificate checking in vSphere 5.1 and after, DNS services must be configured in the backup proxy, otherwise `SSL_Verify` will fail with the “no host found” error.

For incremental backup of virtual disk, always enable changed block tracking (CBT) before the first snapshot. When doing full restores of virtual disk, disable CBT for the duration of the restore. File-based restores affect change tracking, but disabling CBT is optional for partial restore (file level restore), except with SAN transport. CBT must be disabled for SAN writes because of thin-provisioning and clear-lazy-zero operations.

Backup software should ignore independent disks (those not capable of snapshots). These virtual disks are unsuitable for backup. They throw an error if a snapshot is attempted on them.

When using VMware Tools debug logging with quiesced snapshots, do not log `vmtoolsd.data` to a local file on the VM, such as `C:\Temp\vmtoolsd.log`. Instead set `vmtoolsd.handler=vmx` to use the tools service.

To back up thick disk, the proxy's datastore must have at least as much free space as the maximum configured disk size for the backed-up virtual machine. Thick disk takes up all its allocated size in the datastore. To save space, you can choose thin-provisioned disk, which consumes only the space actually containing data.

If you do a full backup of lazy-zeroed thick disk with CBT disabled, the software reads all sectors, converting data in empty (lazy-zero) sectors to actual zeros. Upon restore, this full backup data will produce eager-zeroed thick disk. This is one reason why VMware recommends enabling CBT before the first snapshot.

With CBT enabled for backups on an NFS datastore, thin-provisioned virtual disk may be turned thick upon restore, unless the NFS server supports `lseek(...SEEK_DATA)`, `ioctl(...FS_IOC_FIEMAP)`, or equivalent function.

Do not make verbatim copies of configuration files, which can change. For example, entries in the `.vmx` file point to the snapshot, not the base disk. The `.vmx` file contains virtual-machine specific information about current disks, and attempting to restore this information could fail. Instead use `PropertyCollector` and keep a record of the `ConfigInfo` structure.

Backup and Restore of Thin-Provisioned Disk

Thin-provisioned virtual disk is created on first write. So the first-time write to thin-provisioned disk involves extra overhead compared to thick disk, whether using NBDSSL or HotAdd. This is due to block allocation overhead, not VDDK advanced transports. However once thin disk has been created, performance is similar to thick disk, as discussed in the *Performance Study of VMware vStorage Thin Provisioning*.

When applications perform random I/O or write to previously unallocated areas of thin-provisioned disk, subsequent backups can be larger than expected, even with CBT enabled. In some cases, disk defragmentation might help reduce the size of backups.

About Changed Block Tracking

`VixDiskLib_QueryAllocatedBlocks` returns the sectors of a virtual disk that are in use.

`QueryChangedDiskAreas` returns the sectors that changed since the time of a specified `changeId`.

The current implementation depends on VMFS properties, similar to properties that SAN transport mode uses to locate data on a SCSI LUN. Both rely on unallocated areas (file holes) in virtual disk, and the LazyZero designation for VMFS blocks. Thus, changed block tracking yields best results on VMFS. On other storage types, it could fail, or returns a single extent covering the entire disk.

You should enable changed block tracking in the order recommended by [Enable Changed Block Tracking](#). At first call `VixDiskLib_QueryAllocatedBlocks` to get allocated areas of virtual disk, and back them up. Subsequently call `QueryChangedDiskAreas` to get changed areas, and back them up if they were allocated. If you call `QueryChangedDiskAreas` after a snapshot but before you enable changed block tracking, it also returns unallocated areas of virtual disk. With thin-provisioned virtual disk this could be a large amount of zero data.

The guest operating system has no visibility of changed block tracking. Once a virtual machine has written to a block on virtual disk, the block is considered in use. The information required for tracking is computed when changed block tracking is enabled, and the `.ctk` file is pre-filled with allocated blocks. The mechanism cannot report changes made to virtual disk before changed block tracking was enabled.

HotAdd and SCSI Controller IDs

When using HotAdd backup, always add SCSI controllers to virtual machines in numeric order.

Most systems lack an interface to report which SCSI controller is assigned to which bus ID. HotAdd assumes that the unique ID for a SCSI controller corresponds to its bus ID. This assumption could be false. For instance, if the first SCSI controller on a VM is assigned to bus ID 0, but you add a SCSI controller and assign it to bus ID 3, HotAdd transport may fail because it expects unique ID 1. To avoid problems, when adding SCSI controllers to a VM, the bus assignment for the controller must be the next available bus number in sequence.

Also note that VMware implicitly adds a SCSI controller to a VM if a `bus:disk` assignment for a newly created virtual disk refers to a controller that does not yet exist. For instance, if disks 0:0 and 0:1 are already in place, adding disk 1:0 is fine, but adding disk 3:0 breaks the bus ID sequence, implicitly creating out-of-sequence SCSI controller 3. To avoid HotAdd problems, you should add virtual disks in numeric sequence.

To deal with more disks than can fit on a single controller, you must add some permanent dummy disks to the proxy VM, one on each additional controller that might be needed. Adding only the controller does not cause the controller to remain attached to the proxy VM. A real VMDK must be added on the controller to keep it attached to the proxy VM.

Encrypted VM Backup and Restore

Starting with vSphere 6.5, customers can take advantage of virtual machine encryption. This section describes how to design backup and restore to handle VM encryption.

Encryption protects sensitive parts of a VM and some or all of its virtual disks. The vCenter Server retrieves keys from a key management server and pushes them to ESXi hosts, which use the keys to encrypt virtual disk data, NVRAM, portions of the VMX file, and so forth. See the *vSphere Security* manual for details.

To back up encrypted virtual disks, VDDK obtains the encryption keys and decrypts virtual disk data before copying to backup media, so virtual disk data on backup media are in the clear (not encrypted). VMware recommends that backup agents use their own encryption to protect data on backup media.

Backup of encrypted disks is supported with NBDSSL and HotAdd transport modes, but not supported with SAN transport. To back up encrypted virtual disks using HotAdd, the backup proxy VM must have been encrypted as well. Both NBDSSL backup and HotAdd backup require **Cryptographer.Access** permission, and HotAdd backup mode requires **Cryptographer.AddDisk** also.

Encrypted Virtual Disks

When customers restore virtual disks that were encrypted at backup time, they likely want them to remain encrypted after restore. If a disk was encrypted when it was backed up, the backup agent can remember the storage policy and apply it to the restored disk. If that storage policy no longer exists in the system, the backup agent could ask the administrator what policy to apply for encrypted disks, or use the sample VM encryption storage policy. Optionally the backup agent can remember a disk's key ID and provide it at restore time, which will result in the restored disk using the same key as the original disk. If not specified, vCenter Server gets a new key from the key server.

Recommendations for VM Home

When a VM is encrypted, its VMX configuration file contains portions that are encrypted, and the entire NVRAM file is encrypted. To completely recover a VM from backups, the NVRAM file must be restored, and two additional properties from the VirtualMachine object's configuration must be restored: (1) the encryption key identifier, found in the VirtualMachine `ConfigInfo.keyId` property, and (2) an encrypted blob containing VM secrets, called the `encryption.bundle`, found in the VirtualMachine `ConfigInfo.extraConfig` list.

VMware recommends against directly copying the entire VMX configuration file, but instead using the PropertyCollector to keep a record of configuration structures as documented earlier in this chapter. When a VM is saved, the backup agent should include the `ConfigInfo.keyId`, the `encryption.bundle` from `ConfigInfo.extraConfig`, and the current storage policy.

Later when the backup is restored, these values should be provided in the new `VirtualMachine ConfigSpec`. This will ensure that the recovered VM metadata files are protected with the same key as the original VM. If a VM is restored to a vCenter Server with key server access, the VM will boot. However if the vCenter Server lacks key server access, the VM will not power on after restore, because vCenter Server cannot push encryption keys to its ESXi host.

The NVRAM file can be handled as it was in previous releases, using HTTP download and upload, but without saving the additional `ConfigInfo` properties described above, the NVRAM will be unusable. This is because it is encrypted with the key that is found in the `encryption.bundle`, which is in turn sealed with the key identified by `ConfigInfo.keyId`. The recovered VM must be created in a vCenter Server that has access to the same key server as the original, or a replicated key server instance with the same cluster name.

What If Something Fails

If the `ConfigInfo.keyId` and `encryption.bundle` were not saved, it will be impossible to encrypt the recovered VM using its original encryption keys. However the VM may be encrypted with new keys from the key server. If the NVRAM file was saved, it is unusable without the original `ConfigInfo.keyId` and `encryption.bundle` information. If the NVRAM file was not saved, or unusable, a generic one can be used instead. After NVRAM is lost and regenerated, UEFI enabled VMs may require Secure Boot to be reconfigured, or the boot disk to be reconfigured.

If the vCenter Server has lost access to the original keys from the key server, then a restore operation may remove the `encryption.bundle` from `ConfigInfo.extraConfig` and specify only a VM encryption storage policy for the VM and its disks. Again this will cause any data present in the NVRAM to be unusable.

Backup and Restore With vTPM

Trusted platform module (TPM) is the standard for a dedicated microchip that can store sensitive data, perform cryptographic tasks, and ensure platform integrity by establishing a chain of trust for software loaded onto a machine. It assures integrity by calculating a message digest for each software component that gets loaded, storing the message digest in platform configuration register.

Enabling vTPM in a Virtual Machine

Virtual TPM (vTPM) is a software implementation of TPM provided in virtual hardware version 14. In other words, vSphere 6.7 offers vTPM for newly created or upgraded VMs. Because vTPM is encrypted, encryption services must be present on the network. Backup and restore of a vTPM enabled VM is similar to backup and restore of an encrypted VM, with these additional requirements.

- Each involved vCenter Server must be configured with the same key management server (KMS).

- Before adding the vTPM device to a VM, the `ConfigInfo.firmware` type must be set to `efi`, not `bios`. When you add a VM with encryption storage policy, vSphere encrypts the VM Home including vTPM.
- To preserve vTPM in a restored VM, the `ConfigInfo.keyId`, `encryption.bundle`, NVRAM file, and vTPM device of the source VM must be saved at backup time, for later restore. Saving an NVRAM file requires use of the HTTP file service.

Backup with vTPM

To back up a vTPM enabled VM, follow these steps, as in the sample code below.

- 1 Back up the `keyId` and `encryption.bundle` of the source VM from `configInfo`.
- 2 Back up the vTPM device of the source VM from `configInfo`.
- 3 Back up property `firmware` of the source VM from `configInfo`.

```
// get source VM config
VirtualMachineConfigInfo sourceVmConfigInfo = ... ;
// save keyId
CryptoKeyId keyId = sourceVmConfigInfo.getKeyId();
// save encryption.bundle, which is in extraConfig
List<OptionValue> extraCfg = sourceVmConfigInfo .getExtraConfig();
// save firmware
String firmware = sourceVmConfigInfo.getFirmware();
// save vTPM device
VirtualDevice vtpmDevice = null;
for (VirtualDevice virtualDevice : sourceVmConfigInfo.getHardware().getDevice()) {
    if (virtualDevice instanceof VirtualTPM) {
        vtpmDevice = virtualDevice;
    }
    // save other devices
    // ...
}
// save nvrAm file
byte[] nvrAmByteAry = vsphereFileServiceClient.download(sourceVmNvrAmFilePath);
```

Restoring With vTPM

To restore a vTPM enabled VM, follow these steps, as in the sample code below.

- 1 Configure a VM with the same `keyId` and `encryption.bundle` as source (requires same KMS).
- 2 Make sure an encryption storage policy exists and is assigned to the VM. See "Create an Encryption Storage Policy" in the *vSphere Web Services SDK Programming Guide*.
- 3 Configure this VM with the same `firmware` property and vTPM device as the source VM.

- 4 Restore NVRAM using HTTP service. Again, see section "HTTP Access to vSphere Server Files" in the *vSphere Web Services SDK Programming Guide*.

```
// create configSpec for VM to be created
VirtualMachineConfigSpec configSpec = new VirtualMachineConfigSpec() ;
// set keyId
CryptoSpecEncrypt cryptoSpec = new CryptoSpecEncrypt();
cryptoSpec.setCryptoKeyId(keyId);
configSpec.setCrypto(cryptoSpec);
// set encryption.bundle
configSpec.setExtraConfig(extraCfg);
//
// set PbmProfile for encryption
// For complete code, see Example: Java program to set storage policy for encryption.
// public class CreateVMEncryptionProfile extends ConnectedServiceBase {
// private PbmServiceInstanceContent spbmisc;
// private String profileName;
// ...
// for (PbmCapabilityVendorResourceTypeInfo vendor : vendorInfo)
//     for (PbmCapabilityVendorNamespaceInfo vnsci : vendor .getVendorNamespaceInfo())
//         if (vnsci.getNamespaceInfo().getNamespace().equals("vmwarevmcrypt")) {
//             encryptionCapable = true;
//             break;
//         }
//     }
// ...
// set firmware
configSpec.setFirmware(firmware);
// set vTPM device
VirtualDeviceConfigSpec vtpmDeviceConfig = new VirtualDeviceConfigSpec();
vtpmDeviceConfig.setOperation(VirtualDeviceConfigSpecOperation.ADD);
vtpmDeviceConfig.setFileOperation(null);
vtpmDeviceConfig.setDevice(vtpmDevice);
configSpec.getDeviceChange().add(vtpmDeviceConfig);
// set other properties and then create restore VM
// ...
// upload nvram
vsphereFileServiceClient.upload(restoreVmNvramFilePath, nvramByteArray
```

Windows Backup Implementations

The following sections discuss issues when backing up Windows virtual machines.

Disable Automount in Windows Proxy

When using HotAdd transport from a Windows proxy, it can make unwanted changes to HotAdded volumes. To prevent this, backup vendors and customers should disable Windows automount on the backup proxy.

To disable Windows automount

Procedure

- 1 Start DiskPart.

```
C:\> diskpart
```

- 2 Disable automounting.

```
DISKPART> automount disable
```

- 3 Prevent any previously mounted volumes from being re-mounted the next time.

```
DISKPART> automount scrub
```

- 4 Exit DiskPart.

```
DISKPART> exit
```

Security and Remote Desktop

For security reasons, remote desktop protocol (RDP) should be disabled on a Windows proxy.

Working with Microsoft Shadow Copy

Microsoft Shadow Copy, also called Volume Snapshot Service (VSS), is a Windows Server data backup feature for creating consistent point-in-time copies of data (called shadow copies).

The type of quiescing used varies depending on the operating system of the backed-up virtual machine, as shown in [Table 7-5](#). ESXi 4.1 added support for Windows 2008 guests using application level quiescing.

Table 7-5. Driver Type and Quiescing Mechanisms Used According to Guest Operating Systems

Guest Operating System	Driver Type Used	Quiescing Type Used
Windows XP 32-bit Windows 2000 32-bit	Sync Driver	File-system consistent quiescing.
Windows Vista 32- or 64-bit Windows 7 32- or 64-bit	VMware VSS component	File-system consistent quiescing.
Windows 2003 32- or 64-bit	VMware VSS component	Application-consistent quiescing.

Table 7-5. Driver Type and Quiescing Mechanisms Used According to Guest Operating Systems (Continued)

Guest Operating System	Driver Type Used	Quiescing Type Used
Windows 2008 32- or 64-bit Windows Server 2008 R2	VMware VSS component	Application-consistent quiescing. For this to be available, several conditions must be met: <ul style="list-style-type: none"> Virtual machine must be running on ESXi 4.1 or later. The UUID attribute must be enabled. It is enabled by default for virtual machines created on 4.1 or later. For details see Enable Virtual Machine Application Consistent Quiescing. The virtual machine must use SCSI disks only and have as many free SCSI slots as the number of disks. Application-consistent quiescing is not supported for virtual machines with IDE disks. The Windows VM must not use dynamic disks. If the VM has dynamic disks, the snapshot will be file-system consistent.
Windows Server 2012	VMware VSS component	Same as for Windows 2008.
Windows Server 2016	VMware VSS component	Same as for Windows 2008. VMware Tools 10.1.0 or later is required for quiescing support. Application quiesced snapshots are not supported for virtual disks managed by Storage Spaces. Use file-system quiescing as a workaround.
Other guest operating system	Not applicable	Crash-consistent quiescing.

File-system consistent quiescing prevents file systems from becoming corrupted, for example, journaled file systems are allowed to write out pending transactions. Crash-consistent quiescing is the ability to restore an application as if it suddenly crashed and lost all stateful information. This involves minimal effort because only data already written to disk is guaranteed safe. Application-consistent quiescing is the ability to restore stateful information as well.

Restore must be done using the backup application's guest agent. The vSphere APIs for Data Protection provide no host agent support for this. Applications authenticating with SSPI might not work right because HTTP access will demand a user name and password, unless the session was recently authenticated.

When performing VSS quiescing while creating the snapshot of a Windows virtual machine, VMware Tools generate a `vss-manifest.zip` file containing the backup components document (BCD) and writer manifests. The host agent stores this manifest file in the `snapshotDir` of the virtual machine. Backup applications should get the `vss-manifest.zip` file so they can save it to backup media. There are several ways to get this file:

- Using the datastore access HTTPS protocol, for example by browsing to `https://<server-or-host>/folder/` and continuing downward to the snapshot directory until you find the `vss-manifest.zip` file.
- By calling the `CopyDatastoreFile_Task` method in the vSphere API. This method accepts the URL formulated above for HTTPS, or a datastore path. (`CopyVirtualDisk_Task` is for VMDK files).
- With the `vifs` command in the vMA or vCLI.

- With the `Copy-DatastoreItem` cmdlet in the PowerCLI (requires PowerShell and VMware snap-in).

Windows 2008 application level quiescing is performed using a hardware snapshot provider. After quiescing the virtual machine, the hardware snapshot provider creates two redo logs per disk: one for the live virtual machine writes and another for the VSS and writers in the guest to modify the disks after the snapshot operation as part of the quiescing operations.

The snapshot configuration information reports this second redo log as part of the snapshot. This redo log represented the quiesced state of all the applications in the guest. This redo log must be opened for backup with VDDK 1.2 or later. The older VDDK 1.1 software cannot open the second redo log for backup.

Application consistent quiescing of Windows 2008 virtual machines is only available when those virtual machines are created in vSphere 4.1 or later. Virtual machines created in vSphere 4.0 can be updated to enable application consistent quiescing by modifying a virtual machine's `enableUUID` attribute.

For information about VSS, see the Microsoft TechNet article, *How Volume Shadow Copy Service Works*. For information about Security Support Provider Interface (SSPI), see the MSDN Web site.

Enable Virtual Machine Application Consistent Quiescing

To enable virtual machine application consistent quiescing on Windows 2008 or later:

Procedure

- 1 Start the vSphere Client, and log in to a vCenter Server.
- 2 Select **Virtual Machines and Templates** and click the **Virtual Machines** tab.
- 3 Right-click the Windows 2008 virtual machine for which you are enabling the disk UUID attribute, and select **Power > Power Off**. Wait for the virtual machine to power off.
- 4 Right-click the virtual machine, and click **Edit Settings**.
- 5 Click the **Options** tab, and select the **General** entry in the settings column.
- 6 Click **Configuration Parameters...** The Configuration Parameters window appears.
- 7 Click **Add Row**.
- 8 In the Name column, enter `disk.EnableUUID`. In the Value column, enter **TRUE**.
- 9 Click **OK** and click **Save**.
- 10 Power on the virtual machine.

Application consistent quiescing is available for this virtual machine after the UUID property is enabled.

Application-Consistent Backup and Restore

Here is the approximate procedure for software to performs application-consistent backup and restore:

Procedure

- 1 Call `CreateSnapshot_task` with the quiescent flag set true.
- 2 Open the leaf node of the disk with VDDK and read both the base VMDK and the snapshot at once.
- 3 Delete the snapshots created in the first step.
- 4 During restore, create a new virtual machine.
- 5 Write the VMDK to disk with VDDK. It should have both base and quiesced information.

During backup, if the snapshot was created with quiesce flag set to true, and all the quiescing conditions are met, so the snapshot is created involving VSS and the snapshot disks represent application consistent state of the guest OS. You should be able to confirm this by downloading the `VSS manifest.zip` file, unzipping it to check if it has just the backup component document (in which case file system quiescing was performed) or also writer manifests (in which case application quiescing was performed).

Quiescing involves the VSS mechanism designed by Microsoft. So, regarding VSS backup-restore verification, refer to the VSS documentation provided by Microsoft. VMware helps by providing a `vss-manifest.zip` file that contains Backup/Writers Components details. This is generated by the VSS mechanism after backup. By cross verifying these backup/writers components details according to Microsoft VSS documentation, you can verify if a particular application-consistent quiescing was completed successfully or not.

VMware Tools is responsible for initiating the VSS snapshot process as the VSS requester. Users send a request to `hostd` for a quiesced snapshot of the virtual machine. The request goes from `hostd` to the VMware Tools for a VSS snapshot. Once the VSS snapshot is completed (with success or error) it communicates back to the `hostd` process. The VSS snapshot is created with the `vss-manifest` file, or without this file in the error case.

The VSS requester sets up the overall configuration for the backup operation, including whether the snapshot should be performed in component mode or not, whether to take a snapshot with a bootable system state, and whether the snapshot should be for a full copy or differential backup. If application-consistent quiescing is performed, then all writers and all components are involved.

VMware Tools initiates VSS quiescing using `VSS_CTX_BACKUP` context for application quiescing capable guests with backup state set to select components, backup bootable system state with backup type `VSS_BT_COPY` and no partial file support and `VSS_CTX_FILE_SHARE_BACKUP` for file system quiescing capable guests. Currently there is no way to control any of these parameters.

New VSS Support Added in vSphere 6.5

The vSphere 6.5 release includes additional volume shadow-copy service (VSS) configurations and features. To support these new configuration and for more granular control over Windows guest OS quiescing, the function `CreateSnapshotEx_Task` was added to the 6.5 vSphere API, superseding `CreateSnapshot_Task`. `CreateSnapshotEx_Task` takes a `quiesceSpec` parameter, of type `VirtualMachineGuestQuiesceSpec` or `VirtualMachineWindowsQuiesceSpec`. The latter type can specify several important fields such as:

- `vssBackupType` – `VSS_BT_COPY` was previously used as the default for `CreateSnapshot_Task` but now `VSS_BT_FULL`, `VSS_BT_INCREMENTAL`, `VSS_BT_DIFFERENTIAL`, and `VSS_BT_LOG` are available also. Log truncation may be triggered according to application settings.
- `vssBackupContext` – this was introduced to enforce application (context `VSS_CTX_BACKUP`) quiescing or file system (context `VSS_CTX_FILE_SHARE_BACKUP`) quiescing.
- The timeout (default 15 minutes) for quiescing virtual machines can now be configured anywhere from five minutes to four hours.

`CreateSnapshotEx_Task` requires VMware Tools 10.1.0 or higher installed on the backed-up virtual machine.

The VMware VSS Implementation

As of Windows Server 2008, disk UUIDs must be enabled for VSS quiesced snapshots. Disk UUIDs might not be enabled if a virtual machine was upgraded from virtual hardware version 4.

VMware VSS does not support virtual machines with IDE disks, nor does it support virtual machines with an insufficient number of free SCSI slots.

Before vSphere 5.1, reverting to a writable snapshot sometimes left orphaned virtual disks that the system never removed. In the vSphere 5.1 release, writable snapshots are correctly accounted for as sibling snapshots. This permits cleaner management, because the disk chain matches the snapshot hierarchy, and it avoids orphaned disks. Linux backup software takes a read-only snapshot so is not affected. On Windows, VSS backup software may create two snapshots, one made writable by calling `CreateSnapshot_task` with the `quiesce` flag set true.

To add support for granular application control, specify:

- whether pre-freeze and post-thaw scripts get invoked
- whether quiescing gets invoked
- VSS snapshot context (application, file system quiescing, and so forth)
- VSS backup context (full, differential, incremental)
- writers/components to be involved during quiescing
- whether to fail quiescing or continue if one of the writers fails to quiesce
- retry count

A VSS quiesced snapshot reports as VSS_BT_COPY to VSS, hence no log truncation. The VSS manifest can be downloaded with HTTP. By default, all VSS writers are involved, but a mechanism for excluding writers exists; see the VMware KB article 1031200. For help troubleshooting, see KB article 1007696.

Linux Backup Implementation

On Linux virtual machines, VMware supports only crash-consistent backups, however application-consistent backups are possible through the use of customer pre-freeze and post-thaw scripts.

Two methods are attempted sequentially when a quiesced snapshot is requested of a Linux virtual machine:

Procedure

- 1 Using the `ioctl(2)` mechanisms FIFREEZE and FITHAW built into the Linux kernel.

This option is available in only with kernel versions newer than 2.6.32 on Linux virtual machines running VMware Tools 5.x or higher (vSphere 5.0 and later).

- 2 Using the `sync(2)` system call.

The first method allows you define custom scripts that get called by VMware Tools before and after quiesce. Here are two commands that can be called from pre-freeze and post-freeze scripts:

```
# -f means freeze
fsfreeze -f /

# -u means unfreeze
fsfreeze -u /
```

The mount point used in the scripts (root in the examples above) must be mounted with the `noatime` option, meaning do not update inode access times on the file system, for freeze and unfreeze to work.

Backing Up vApps in vCloud Director

8

This chapter introduces developers to the concepts and procedures for creating backup and restore solutions for vCloud Director. This chapter is divided into the following main sections:

This chapter includes the following topics:

- [Introduction to Tenant vApps](#)
- [Conceptual Overview](#)
- [Use Cases Overview](#)
- [vCloud API Operations](#)
- [Conclusion](#)

Introduction to Tenant vApps

The vApp is a management construct that encapsulates one or more virtual machines running in the vSphere environment. The tenant vApp is a higher-level construct that allows vCloud Director to manage vApps and virtual machines running in a multi-tenant datacenter, or in a multi-tenant cloud, based on vSphere.

[Figure 8-1](#) shows the objects within a single organization that you can access with the vCloud API.

Figure 8-1. vCloud API Object Taxonomy

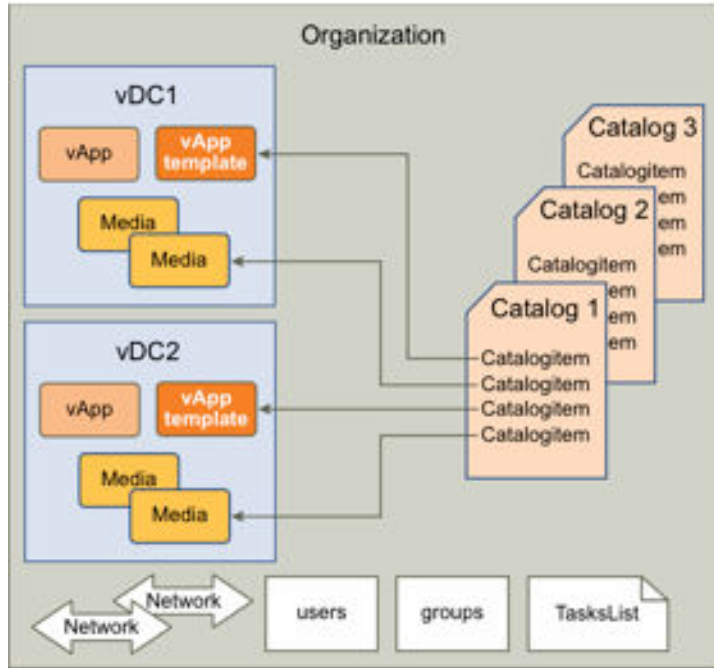

Multi-tenant and self-service capabilities of vCloud Director provide multiple levels of protection for a vApp. A service provider can offer vApp protection at the system level, the tenant level, or the end-user level, managed by the system administrator, Organization administrator, and end user, respectively. This chapter focuses on the protection provided at the system level, where service providers can employ backup solutions from vendors of data protection software.

This chapter describes how to design software to back up and restore the vApps in a vCloud. To back up or restore a vApp, you need to deal with both the vCloud configuration and the virtual machines that belong to the vApp. In vSphere, a virtual machine is represented by configuration files and virtual disk files.

Prerequisites

You should be familiar with programming concepts and techniques. You should also be familiar with vCloud, vCloud API, vCloud SDK for .NET, and vSphere concepts. VMware also provides the vCloud SDK for Java and the vCloud SDK for PHP, but this chapter focuses on .NET for the backup and restore examples.

VMware recommends that you design backup and restore software for the vCloud environment using the following APIs:

Table 8-1. APIs Used To Back Up vApps

Product	API	Data
vCloud Director	vCloud API or vCloud SDK wrapper	vApp metadata
vSphere	WS API	virtual machine configuration
VDDK	VixDiskLib API or VixMntapi	virtual disk contents

You use the vCloud API or SDK to identify vApp targets for backup and restore operations. The vApp metadata identifies the virtual machines that constitute the vApp. You use the WS API to back up and restore virtual machine configurations. You use the VDDK API to back up and restore virtual disk files.

Note This chapter uses the term “metadata” in a general sense to mean all the vApp configuration data, in addition to user-defined data that the vCloud REST API serializes in the <Metadata> element.

You should be familiar with the use of the WS API and the VDDK API for backup and restore of individual virtual machines.

Other Information

This chapter does not, in general, duplicate information available in other documents. In particular, this chapter does not provide details about any storage or data protection API that you need to use for backing up and restoring virtual machines in vSphere. You should consult separate reference documentation for details about specific API calls.

This chapter emphasizes the use of the vCloud API and SDK for the purpose of managing metadata of the virtual machines and related artifacts in vCloud Director. The vCloud SDK for .NET translates your C# code into REST operations using the vCloud API.

To learn about VMware vCloud and vSphere concepts and usage, refer to the vCloud Director documentation available from the VMware Web site, http://www.vmware.com/support/sdk_pubs.html. You can also visit the VMware SDK community forum at <http://communities.vmware.com/community/vmtn>.

Conceptual Overview

This section summarizes the backup and restore processes for vApps managed by vCloud Director. It explains how to use VMware APIs to collect the metadata needed to control backup and restore operations. The actual backup and restore operations are performed using the VMware vStorage APIs for Data Protection (VADP).

VMware vCloud Director uses one or more vCenter servers to manage virtualized resources. At the same time, it manages the vCloud feature of multi-tenancy by maintaining metadata related to various tenant artifacts such as vApp, users, networks, storage, and so on.

When a system administrator chooses to back up a vApp, certain vApp metadata must be retrieved from vCloud Director. The metadata includes general information about the vApp (name, description, virtual machine descriptions), networking information (organization network connectivity, external network connectivity), user information, lease, and quota. This information becomes particularly important when restoring the vApp, in addition to the names of virtual disk files and .vmx files typically retrieved from vSphere using the VADP.

The Backup Process

The backup process requires the backup/restore software to collect and store information both from vCloud Director and from vSphere. This process assumes that you use vCloud Director system administrator credentials to connect to vCloud Director. System administrator credentials allow the software to access vApps belonging to any Organization, and to access all the necessary information about a vApp and associated vCloud constructs.

A vApp in vCloud Director can comprise one or more virtual machines. When you work with a single vApp in vCloud Director, you might be working with a number of virtual machines in vSphere.

To back up a vApp or set of vApps:

Procedure

- 1 Connect to vCloud Director and access the organization where vApp (or vApps) will be backed up.
- 2 When backing up a vApp for a given Organization or VDC in vCloud Director, access the vCloud Director inventory for a list of all desired vApps.
- 3 Select maintenance mode for each vApp to prevent updates during the backup process.
- 4 Collect all the metadata related to the vApp(s), including any user-defined metadata associated with any given vApp.
- 5 Use the vApp metadata to identify the virtual machines associated with each vApp.
- 6 Connect to vCenter Server as a user with sufficient permissions to access the virtual machines. Use the vSphere inventory to locate the virtual machine configuration and virtual disk files.
- 7 Use the VMware APIs for Data Protection to back up the vSphere virtual machine files:
 - a (optional) Save a snapshot of the virtual machine.
 - b Save the virtual machine configuration, using the WS API.
 - c Save the virtual disks using the VDDK API.
 - d (optional) Delete the virtual machine snapshot, if applicable.
- 8 Store the vApp metadata in an appropriate format along with the associated virtual machine files.
- 9 Deselect maintenance mode for each vApp.

The Restore Process

The restore process offers some options to the administrator.

When you restore a vApp, you can choose to overwrite an existing vApp. For instance, the restore software might need to overwrite a vApp with data corruption. You can also choose to restore a vApp that no longer exists, for instance, a vApp that was accidentally deleted.

You can choose whether to keep the same vApp name and other vApp attributes, or you can choose to change attributes during the restore process. If the attributes of the restored vApp no longer conform to the environment because of changes since the backup was taken, you can select new values for the non-conforming attributes.

You might want to restore an existing vApp to an earlier state, or you might want to replace it because it has become corrupted.

To restore an existing vApp:

- 1 Identify the child virtual machines of the vApp, using the metadata stored with the backup.
- 2 Connect to vCenter Server as a user with sufficient permissions to access the virtual machines and restore the virtual machines in the vSphere environment. This step restores the virtual disk files and virtual machine configuration. If you are overwriting an existing vApp, you generally restore the files to the same data store that vCloud Director currently uses for the vApp.
- 3 Connect to vCloud Director and authenticate as an administrator, which gives you backup and restore privileges.
- 4 Locate the corrupted vApp, using the ID retrieved from the metadata in the backup store.
- 5 Select maintenance mode for the vApp, to prevent changes while restoring metadata.
- 6 Edit vApp settings such as network, user privileges, lease, and quota as needed. Make sure to include any user-defined metadata from the backup store. If you restored a virtual machine to a different location from the original, you might need to adjust the vApp settings.
- 7 Deselect maintenance mode for the vApp.

You might want to restore a missing vApp because somebody deleted it, or as part of disaster recovery.

To restore a missing vApp:

- 1 Identify the child virtual machines of the vApp, using the metadata stored with the backup.
- 2 Connect to vCenter Server as a user with sufficient permissions to access the virtual machines and restore the virtual machines in the vSphere environment. This step restores the virtual disk files and virtual machine configuration.
- 3 Connect to vCloud Director and authenticate as an administrator, which gives you backup and restore privileges.
- 4 Compose a new vApp or import the virtual machine(s) into vCloud Director to create a new vApp with these characteristics:
 - a It has the same name as the lost vApp.
 - b It belongs to the same Organization as the lost vApp.
 - c It obtains resources from the same provider VDC as the lost vApp.
- 5 Select maintenance mode for the vApp, to prevent changes while restoring metadata.
- 6 Edit vApp settings such as network, user privileges, lease, and quota as needed. Make sure to include any user-defined metadata from the backup store.

7 Deselect maintenance mode for the vApp.

Note This is a simplified view of the restore process. The exact process you use will depend on the features provided by your software. For instance, if the datastore is full, the software could offer to migrate the vApp to a different datastore.

Use Cases Overview

The following sections give an overview of use cases related to the backup and restore processes.

Managing Credentials

Backup software needs vCloud Director access to manage vApps at the metadata level, and vCenter Server access to manage vApps at the virtual machine and virtual disk level. The backup software must collect and retain authentication credentials for both vCloud Director and vCenter Server.

For information about vCloud Director authentication, see [Getting Access to vCloud Director](#). For information about vSphere authentication, see the *vSphere Web Services SDK Programming Guide*.

Finding a vApp

There are different ways to locate a vApp managed by vCloud Director. One way is to traverse the vCloud Director inventory. Another way is to use the query service.

Inventory Traversal

Using the vCloud Director inventory to locate a vApp requires navigating a hierarchy of containers based on organizational and resource divisions. The process is explained in [Inventory Access](#).

Using the Query Service

The vCloud SDK for .NET also supports the query service of the vCloud API for finding vApps. Consult the sample programs in the SDK for more information about how to use the query service in the SDK.

Protecting Specified vApps

Backup systems typically identify vApps to be backed up in a given Organization based on their identity, using vApp attributes such as name and ID or user defined metadata. A set of vApps to be backed up can also be created based on their Organization (for example, all vApps in the Human Resources Organization), the VDC where they are deployed, and so forth.

In all these cases you must traverse the given Organization and its contents to locate and make a list of vApps.

Recovering an Older Version of a vApp

If a vApp has become corrupted, or if users need to revert to an older state of the vApp, the administrator can restore a version of the vApp from backup storage even when the vApp still exists in vCloud Director. The backup/restore application in these cases can access vCloud Director to get vApp identity information and metadata before restoring the backup copy.

The backup/restore application has a choice between overwriting the current vApp instance or deleting it and creating a new vApp. The choice to delete the vApp can be convenient when the vApp configuration has changed since the last backup, especially when a virtual machine has been added to or deleted from the vApp.

Recovering a Deleted vApp

When recovering a deleted vApp, the backup/restore application must identify the vApp from user input to locate the vApp metadata and virtual machine files on the backup storage medium. After the virtual machines have been restored using vSphere APIs, the vApp can be recomposed using the vCloud API. The backup software must first create a vApp from one of the virtual machines, then import the remaining virtual machines into the same vApp.

Recovering a Single Virtual Machine

The process of recovering a single virtual machine from the backup storage medium is a special case of recovering a deleted vApp. In the case of a deleted vApp, the backup software must re-create the vApp in vCloud Director, then import the remaining virtual machines. For a single lost virtual machine, the backup software must only import the one virtual machine into the existing vApp.

Backing Up vCloud Director

The vCloud SDK for .NET does not offer any special features for backing up or restoring the vCloud Director application and its data. Users should follow standard industry advice for protecting Tomcat applications and Oracle or SQL Server databases.

vCloud API Operations

The following sections describe commonly used vCloud API operations using vCloud SDK for .NET. The API descriptions in this chapter do not provide complete backup/restore implementation details, but focus instead on identifying a set of vCloud API methods that facilitate certain operations that use vCloud Director.

You should be familiar with vCloud Director and vCloud API concepts. Every resource in vCloud Director can be accessed using either its unique ID or HREF (the reference URL) in the vCloud API. The .NET SDK provides wrapper utility classes for commonly-used resources to make the programming easier.

The operations described in the following sections are:

- [Getting Access to vCloud Director](#) – Shows how to connect and authenticate with the vCloud API.

- [Inventory Access](#) – Shows how to retrieve data for different Organization types.
- [Retrieving Catalog information](#) – Shows how to retrieve Catalog entries for backup.
- [Retrieving vApp Configuration](#) – Shows how to list virtual machines and vApp configuration data.
- [Preventing Updates to a vApp During Backup or Restore](#) – Shows how to use maintenance mode to quiesce vApp configuration.
- [Associating vCloud Resources with vSphere Entities](#) – Shows how to get Managed Object References of virtual machines and storage resources from vCloud Director.
- [Restoring vApps](#) – Shows how to import virtual machines into vApps.

Getting Access to vCloud Director

The backup/restore software component must use system administrator privileges to connect to vCloud Director, so that it can access any Organization. The system administrator always logs into the System organization. When Administrator@System is used as the user name for the API, Administrator is the login name and System is the System Organization name.

Using system administrator privileges to connect to vCloud Director also allows the backup/restore software to access additional information relating a vApp to the corresponding resources in vSphere. This is described in [Inventory Access](#).

The following example shows how to log in using C# with the vCloud SDK for .NET. After logging in, the code shows how to access Organization data.

```
// vCloud Director login code sample using Administrator@System/<password>
using com.vmware.vcloud.sdk;
using com.vmware.vcloud.api.rest.schema;

public static vCloudClient client = null;
client = new vCloudClient(vCloudURL, com.vmware.vcloud.sdk.constants.Version.V1_5);
client.Login(username, password);
// Get references to all Organizations:
Dictionary<string,ReferenceType> organizationsMap = client.GetOrgRefsByName();
// Get reference to a specific Organization:
string orgName = "Org1";
ReferenceType orgRef = client.GetOrgRefByName(orgName);
// Convert Organization reference to Organization object:
Organization org = Organization.GetOrganizationByReference(client, orgRef);
```

Inventory Access

In general, you locate a desired vApp for backup in the context of a given Organization and VDC. To locate a vApp that you want to back up, you first need a reference to its parent Organization.

You use the Organization reference to get the Organization object, which you use to get a list of references to the VDCs that belong to the Organization. You use a VDC reference to get a VDC object, which you then use to get a list of references to the vApps that belong to the Organization. You convert the desired vApp reference to a vApp object, which you use to list the virtual machines that belong to the vApp.

The following example shows how to get a reference to the user view of an Organization, and how to get a reference to the admin view of an Organization and a VDC.

```
// Get admin Org and vDC
public static vCloudClient client = null;
// Login
...
// Get admin view of Org
VcloudAdmin admin = client.GetVcloudAdmin();
string orgName = "Org1";
ReferenceType orgRef = admin.GetAdminOrgRefByName(orgName);
AdminOrganization adminOrg = Organization.AdminGetOrgByReference(client, orgRef);
// Get admin vDC
string vdcName = "VDC1";
ReferenceType vdcRef = adminOrg.GetAdminVdcRefByName(vdcName);
...
AdminVdc adminVdc = AdminVdc.GetAdminVdcByReference(client, vdcRef);
```

Admin Views

The admin view of resources such as Organization, VDC, and vApp provides extra information that is useful to users with administrative privileges. For example, in the case of a vApp, admin view provides information about vCenter and the virtual machines that belong to the vApp. The admin view provides information such as Managed Object References that vCenter uses for those entities. See [Associating vCloud Resources with vSphere Entities](#) for more information about getting vCenter Managed Object References.

To access admin views, you use a method of the client connection object to create an admin client proxy. The admin proxy has methods similar to those of the client connection object to get references to Organizations and other vCloud objects. However, the objects you get from the admin proxy have additional properties not present in user objects.

Admin Extensions

Similar to the admin views, you can use a different method of the client connection object to create an admin extension client proxy. You use the admin extension proxy to find provider VDC. A provider VDC includes one or more resource pools and allocates resources from those pools to the Org VDCs that it supports.

The following example shows how to get a Provider VDC.

```
// Login
...
// Get dictionary of Provider VDCs:
AdminExtension.VcloudAdminExtension adminExt = client.GetVcloudAdminExtension();
string pvdcName = "ProvVDC1";
Dictionary<string, ReferenceType> refs = adminExt.GetVMWProviderVdcRefsByName();
...
// Get reference for pvdcName -> pvdcRef
ReferenceType pvdcRef = refs[pvdcName];
VMWProviderVdc vmwPvdc = VMWProviderVdc.GetVMWProviderVdcByReference(client, pvdcRef);
```

Using the vCloud SDK for .NET allows you to access vCloud Director from a C# development environment. These examples show how to use .NET methods. The vCloud SDK for .NET simplifies access to the vCloud API. For more information about using the SDK, see the *vCloud SDK for .NET Developer's Guide*.

The vCloud API is REST-based. For more information about the vCloud API, see the *vCloud API Programming Guide*. The following example shows the REST API calls that accomplish the tasks shown in examples above, after logging in. RESA API Calls To Get Provider VDC:

```
GET https://vCloud/api/admin
GET https://vCloud/api/admin/org/id
GET https://vCloud/api/admin/vdc/id
GET https://vCloud/api/admin/extension
GET https://vCloud/api/admin/extension/providerVdc/id
```

In general, if you do not need admin views or provider views, you can use an Organization reference to get a VDC reference, and you can use the VDC reference to get a list of vApps belonging to the VDC. The following example shows how to list the hierarchy of Organizations, VDCs, and vApps known to vCloud Director. This example assumes you have already logged in to vCloud Director.

```
// List vApps in a VDC for a Given Organization
Dictionary<string, ReferenceType> organizationsMap = client.GetOrgRefsByName();
if (organizationsMap != null)
{
    foreach (string organizationName in organizationsMap.Keys)
    {
        ReferenceType organizationReference = organizationsMap[organizationName];
        Organization org = Organization.GetOrganizationByReference(client, organizationReference);
        string OrgID = org.Resource.id;
        Console.WriteLine("Organization Name:" + organizationName);
        Console.WriteLine("Organization Id : " + OrgID);
    }
    foreach (ReferenceType orgRef in organizationsMap.Values)
    {
        Organization org = Organization.GetOrganizationByReference(client, orgRef);

        foreach (ReferenceType vdcRef in org.GetVdcRefs())
        {
            Vdc vdc = Vdc.GetVdcByReference(client, vdcRef);
```

```

string vdcId = vdc.Resource.id;
Console.WriteLine("Org vDC Id:" + vdcId);
Console.WriteLine("Org vDC Name:" + vdc.Reference.name);
foreach (ReferenceType vAppRef in Vdc.GetVdcByReference(client, vdcRef).GetVappRefs())
{
    Vapp vapp = Vapp.GetVappByReference(client, vAppRef);
    Console.WriteLine("vApp Id:" + vapp.Resource.id);
    Console.WriteLine("vApp Name:" + vapp.Resource.name);
    List<VM> vms = new List<VM>();
    try
    {
        vms = vapp.GetChildrenVms();
    }
    catch
    {
        // Handle exception here
    }
    foreach (VM vm in vms)
    {
        Console.WriteLine("VM Id : " + vm.Resource.id);
        Console.WriteLine("VM Name : " + vm.Resource.name);
    }
}
}
}
}

```

The .NET SDK code in the following example translates to the API calls shown in the example below this one. REST API Calls To List vApps in a VDC for a Given Organization:

```

GET https://vCloud/api/admin
GET https://vCloud/api/admin/org/id
GET https://vCloud/api/admin/vdc/id

GET https://vCloud/api/admin/extension
GET https://vCloud/api/admin/extension/providerVdc/id

```

You can use a provider VDC reference to enumerate its associated datastores, as shown in the following example, which assumes you have already logged in to vCloud Director. List Datastores:

```

/// <summary>
/// Returns list of Provider vDCs.
/// </summary>
/// <returns>ReferenceType</returns>
public static List<ReferenceType> GetProviderVdc()
{
    List<ReferenceType> vdcRefList = new List<ReferenceType>();
    foreach (ReferenceType vdcRef1 in
        client.GetVcloudAdminExtension().GetVMWProviderVdcRefsByName().Values)
    {
        vdcRefList.Add(vdcRef1);
    }
    return vdcRefList;
}

```

```

}

/// <summary>
/// Returns the list of DataStores
/// </summary>
/// <returns>ReferenceType</returns>
public static List<ReferenceType> GetDataStore()
{
    extension = client.GetVcloudAdminExtension();
    List<ReferenceType> vmDatastorelist = new List<ReferenceType>();
    foreach (ReferenceType datastoreRef in extension.GetVMWDatastoreRefs())
    {
        vmDatastorelist.Add(datastoreRef);
    }
    return vmDatastorelist;
}

// Get the datastores for the list of Provider vDCs.

foreach (ReferenceType providerVdcRef in GetProviderVdc())
{
    string providerVdcId = GetId(providerVdcRef.href);
    Console.WriteLine("Provider vDC Id:" + providerVdcId);
    Console.WriteLine("Provider vDC Name:" + providerVdcRef.name);
    foreach (string morefitem in
        VMWProviderVdc.GetResourcePoolsByMoref(client, providerVdcRef).Keys)
    {
        Console.WriteLine("Moref :" + morefitem);
    }
    foreach (VMWProviderVdcResourcePoolType VcResourcePool in
        VMWProviderVdc.GetResourcePoolsByMoref(client, providerVdcRef).Values)
    {
        string VcResourcePoolId = GetId(VcResourcePool.ResourcePoolVimObjectRef.VimServerRef.href);
        Console.WriteLine("VcResourcePoolId :" + VcResourcePoolId);
    }
}
foreach (ReferenceType item in GetDataStore())
{
    string DatastoreId = GetId(item.href);
    Console.WriteLine("Data Store ID:" + DatastoreId);
    Console.WriteLine("DataStore:" + item.name);
}

```

Retrieving Catalog information

Catalogs on vCloud Director store vApp templates and ISO images as Catalog items. Backup solutions can be asked to back up the items in the Catalog for a given Organization. Catalogs can be shared or private. A user can choose to back up all items or only selected items in the given catalog. For this it is necessary to traverse the given Catalog in an Organization to access the contents and extract the various metadata associated with the vApp.

The following example shows inventory traversal to access the Catalog items in a given Organization, and assumes you have logged in to vCloud Director and obtained a map of Organizations, as in examples above.

```
// List catalogs and catalog items for a given organization:
Console.WriteLine();
if (organizationsMap != null && organizationsMap.Count > 0)
{
    foreach (string organizationName in organizationsMap.Keys)
    {
        ReferenceType organizationReference = organizationsMap[organizationName];
        Console.WriteLine(organizationName);
        Console.WriteLine(organizationReference.href);
        Organization organization = Organization.GetOrganizationByReference(client,
organizationReference);
        List<ReferenceType> catalogLinks = organization.GetCatalogRefs();
        if (catalogLinks != null && catalogLinks.Count > 0)
        {
            foreach (ReferenceType catalogLink in catalogLinks)
            {
                Catalog catalog = Catalog.GetCatalogByReference(client, catalogLink);
                CatalogType catalogType = catalog.Resource;
                Console.WriteLine("    " + catalogType.name);
                Console.WriteLine("    " + catalogLink.href);
                List<ReferenceType> catalogItemReferences = catalog.GetCatalogItemReferences();
                if (catalogItemReferences != null && catalogItemReferences.Count > 0)
                {
                    foreach (ReferenceType catalogItemReference in catalogItemReferences)
                    {
                        Console.WriteLine("        " + catalogItemReference.name);
                        Console.WriteLine("        " + catalogItemReference.href);
                    }
                    Console.WriteLine();
                }
                else
                {
                    Console.WriteLine("        " + catalogLink.href + "No CatalogItems
Found");
                }
            }
            Console.WriteLine();
        }
        else
        {
            Console.WriteLine("No Catalogs Found");
        }
    }
}
else
{
    Console.WriteLine("No Organizations");
}
}
```

The following example shows REST API calls that accomplish some of the tasks shown in the example above. REST API calls to list catalog items:

```
GET https://vCloud/api/catalog/id
GET https://vCloud/api/catalog/id/catalogItems
GET https://vCloud/api/catalogitem/id
```

Retrieving vApp Configuration

For a typical user, a vApp is the basic unit of backup specified in vCloud Director. The current generation of backup software maps vApps to their associated virtual machines in vSphere, and thus the virtual machine becomes an actual artifact. Virtual disk and virtual machine configuration files need to be stored in a backup. Along with the associated virtual machine artifacts, the user needs to back up the metadata and properties associated with every vApp to successfully restore it in vCloud Director when needed.

When a vApp is lost or deleted from vCloud Director, backup software can restore the vApp by composing a new vApp using virtual machines restored in vSphere. In such a case it becomes imperative to restore the properties and metadata associated with the vApp in vCloud Director.

The SDK includes a number of methods that you can use to get vApp configuration information. Although some of this information is included in the OVF used to upload the vApp to vCloud Director, the information might have subsequently been modified either by using the vCloud API or through the user interface.

All of these methods apply to an object of type `Vapp`.

Methods To Retrieve vApp Configuration

- `GetChildrenVms()`
Gets a list of all child virtual machines that constitute a given vApp. Returns `List<VM>`.
- `GetStartupSection()`
Get virtual machine startup information. Returns `StartupSectionType`.
- `GetNetworksByName()`
Get mapping of all the network sections using their name. Returns `Dictionary<string, NetworkSection_TypeNetwork>`.
- `GetNetworkConfigSection()`
Get network configuration details for a vApp. The information typically contains IP scope (gateway, netmask, DNS settings, IP range), Parent network, Fence Mode settings, and so on. Returns `NetworkConfigSectionType`.
- `GetLeaseSettingSection()`
Get lease settings information. It includes deployment and storage lease settings for the vApp. Returns `LeaseSettingsSectionType`.

- `GetOwner()`
Get owner information for the vApp. Returns `ReferenceType`.
- `GetMetadata()`
Every resource in vCloud API can be associated with user-defined metadata. This method returns user-defined metadata associated with a vApp. Returns `MetadataType`.

The following example shows REST API calls used to get vApp configuration data.

```
GET https://vCloud/api/vapp/id
GET https://vCloud/api/vapp/id/startupSection
GET https://vCloud/api/vapp/id/networkConnectionSection
GET https://vCloud/api/vapp/id/networkConfigSection
GET https://vCloud/api/vapp/id/leaseSettingsSection
GET https://vCloud/api/vapp/id/owner
GET https://vCloud/api/vapp/id/metadata
```

Virtual Machine Information

vCloud Director also stores virtual machine configuration information uploaded from an OVF file into a vApp template. If you have not modified a virtual machine configuration since uploading, you can use this information to verify the configuration of the virtual machine before restoring it.

The following methods, applied to an object of type VM, retrieve configuration data structures from vCloud Director.

Configuration Data for a Virtual Machine

- `GetVirtualHardwareSection()`
Get hardware requirements of the virtual machine. Returns `VirtualHardwareSection_Type`.
- `GetOperatingSystemSection()`
Get information about the guest operating system installed on this virtual machine. Returns `OperatingSystemSectionType`.
- `GetNetworkConnectionSection()`
Get information about virtual network devices used by this virtual machine. Returns `NetworkConnectionSectionType`.
- `GetRuntimeInfoSection()`
Get version of VMware Tools installed on the virtual machine. Returns `RuntimeInfoSectionType`.

The following example shows the REST API calls corresponding to the virtual machine configuration sections available from the SDK for .NET. REST API calls to get virtual machine configuration data:

```
GET https://vCloud/api/vapp/id/virtualhardwaresection
GET https://vCloud/api/vapp/id/operatingSystemSection
GET https://vCloud/api/vapp/id/networkConnectionSection
GET https://vCloud/api/vapp/id/runtimeInfoSection
```

Preventing Updates to a vApp During Backup or Restore

While you are backing up or restoring a vApp, you need to prevent updates to the vApp configuration and metadata so that the vApp remains internally consistent. To prevent updates during the backup/restore process, the vCloud API allows the vApp to be placed in maintenance mode, which rejects any new updates to the configuration and metadata.

The backup software must select maintenance mode for the vApp before starting backup or restore operations, and deselect maintenance mode for the vApp after the operations are completed. The following example shows how to protect a vApp by selecting and deselecting maintenance mode.

```
using com.vmware.vcloud.sdk;
using com.vmware.vcloud.api.rest.schema;
...
VApp vapp; // VApp utility class from vCloud SDK
// Identify vApp
vapp.EnableMaintenance(); // Enter maintenance mode
// Perform backup/restore here
...
vapp.DisableMaintenance(); // Exit maintenance mode
```

The following lines show corresponding REST API calls to select and deselect maintenance mode for a vApp.

```
POST https://vCloud/api/vapp/id/action/enterMaintenanceMode
POST https://vCloud/api/vapp/id/action/exitMaintenanceMode
```

Note Selecting maintenance mode does not affect current or pending tasks associated with the vApp. Current or pending tasks will run to completion concurrent with the backup or restore operation. If these tasks involve configuration changes, they could result in an inconsistent vApp configuration. The backup system must ensure that such tasks are complete before storing the vApp properties and metadata.

Associating vCloud Resources with vSphere Entities

The admin view of vCloud Director resources provides additional information about the corresponding entities relevant to the vSphere platform. This information is available only when administrative credentials are used to log in to vCloud Director. The additional information does not replace the use of the vSphere API to provide comprehensive information about the entities. It merely provides the bridge between the vCloud and vSphere by mapping the IDs known to the respective systems.

For example, any given virtual machine is known in vCloud Director by a URN that contains the UUID and resource type. The same resource is identified in vSphere using its native identification, a MoRef (Managed object reference). Additional information provided in the vCloud API makes the necessary link between the two entities by mapping their ID in the two systems. The mapping context is shown in the following figure.

Figure 8-2. Mapping vApp to virtual machine

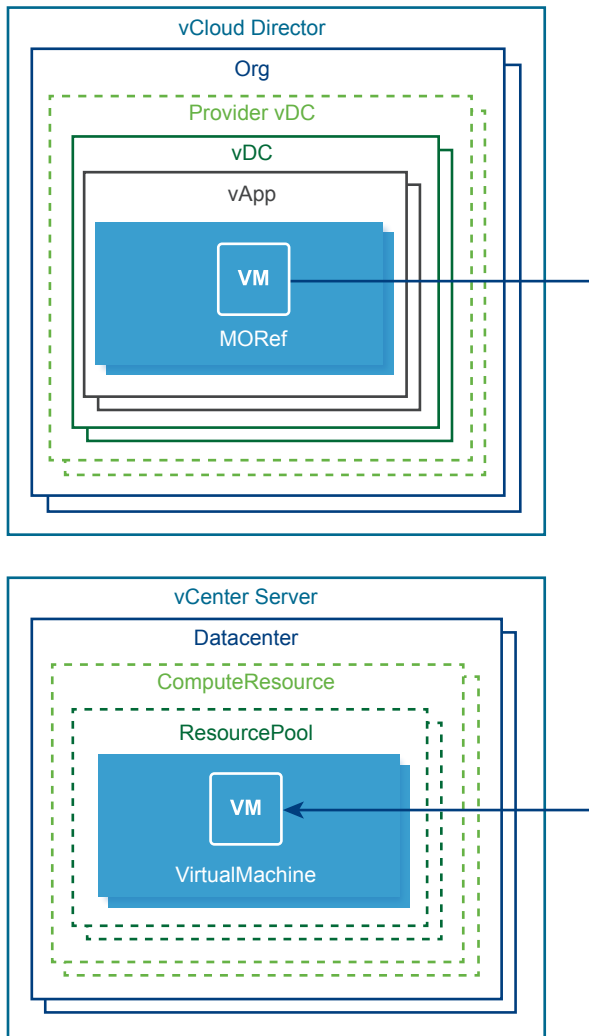

The vCloud API describes the mapping in terms of XML elements, shown in the following example. The box in the example highlights XML data that maps a virtual machine from vCloud Director to vSphere. The MoRef of the virtual machine is in bold type. The object type is shown as VIRTUAL_MACHINE.

```
// XML Mapping a Virtual Machine URL to a MoRef
<Vm needsCustomization="false" deployed="false" status="3" name="RedHat6"
id="urn:vcloud:vm:f487ba71-058a-47a9-9e9a-def458c63fd5" type="application/vnd.vmware.vcloud.vm+xml"
href="https://10.20.140.167/api/vApp/vm-f487ba71-058a-47a9-9e9a-def458c63fd5">
  <VCloudExtension required="false">
    <vmext:VmVmInfo>
      <vmext:VmVmObjectRef>
        <vmext:VmServerRef type="application/vnd.vmware.admin.vmwvirtualcenter+xml"
name="dao_w2k8_vc"
href="https://10.20.140.167/api/admin/extension/vimServer/e7026985-19f6-4b9a-9d0d-588629e63347"/>
          <vmext:MoRef>vm-63</vmext:MoRef>
          <vmext:VmObjectType>VIRTUAL_MACHINE</vmext:VmObjectType>
        </vmext:VmVmObjectRef>
      <vmext:DatastoreVmObjectRef>
        <vmext:VmServerRef type="application/vnd.vmware.admin.vmwvirtualcenter+xml"

```

```

name="dao_w2k8_vc"
href="https://10.20.140.167/api/admin/extension/vimServer/e7026985-19f6-4b9a-9d0d-588629e63347"/>
  <vmext:MoRef>datastore-29</vmext:MoRef>
  <vmext:VmObjectType>DATASTORE</vmext:VmObjectType>
</vmext:DatastoreVmObjectRef>
<vmext:HostVmObjectRef>
  <vmext:VmServerRef type="application/vnd.vmware.admin.vmwvirtualcenter+xml"
name="dao_w2k8_vc"
href="https://10.20.140.167/api/admin/extension/vimServer/e7026985-19f6-4b9a-9d0d-588629e63347"/>
  <vmext:MoRef>host-28</vmext:MoRef>
  <vmext:VmObjectType>HOST</vmext:VmObjectType>
</vmext:HostVmObjectRef>
<vmext:VirtualDisksMaxChainLength>1</vmext:VirtualDisksMaxChainLength>
</vmext:VmVmInfo>
</VCloudExtension>
</Vm>

```

Besides the virtual machine object itself, the `VmVmInfo` element encapsulated in the `VCloudExtension` element of the example lists a datastore object and a host object. Each section provides the vSphere entity reference (`MoRef`) for the corresponding entity, along with its type. The types are `DATASTORE` and `HOST`, respectively. In vCloud Director, the virtual machine can be described as virtual machine `vm-63` stored in datastore `datastore-29` and managed by vCenter Server `dao_w2k8_vc`.

Similarly, the following example shows the administrative view of a VDC wherein the `VCloudExtension` element provides additional information about the corresponding entities in vSphere. In this particular case, the VDC in the example is based on a resource pool configured in vCenter Server, named `dao_w2k8_vc`. More information on this server can be obtained by using the vCloud API and its reference URL, which is available as the `href` property. The `MoRef` element provides the ID of the resource pool that backs the given VDC, as known to vSphere. Since a `MoRef` is treated as an opaque value, the `VmObjectType` element specifies the type of object that the `MoRef` points to. Combining these elements enables you to use the vSphere API and to locate the Resource Pool served by the specified vCenter Server. XML mapping a datacenter URL to a `MoRef`:

```

<AdminVdc ... >
  <VCloudExtension required="false">
    <vmext:VmObjectRef>
      <vmext:VmServerRef
type="application/vnd.vmware.admin.vmwvirtualcenter+xml" name="dao_w2k8_vc"
href="https://10.20.140.167/api/admin/extension/vimServer/e7026985-19f6-..." />
      <vmext:MoRef>resgroup-52</vmext:MoRef>
      <vmext:VmObjectType>RESOURCE_POOL</vmext:VmObjectType>
    </vmext:VmObjectRef>
  </VCloudExtension>
  ...
</AdminVdc ... >

```

The following example shows how to use SDK helper methods to access the vSphere specific information for the virtual machines of a given vApp.

The return value of the methods has type `VimObjectRefType`, which provides a reference to a vCenter Server, a `MoRef` to the vSphere entity, and the type of the entity it is referring to.

```
// Using the SDK for .NET To Access MoRefs
using com.vmware.vcloud.sdk;
using com.vmware.vcloud.api.rest.schema;
...
// Log in with admin privileges and get admin view of vDC containing the vApp.
...

VApp vapp; // VApp utility class from vCloud SDK
// Identify vApp.
...

List<VM> Vms;
// Get list of children VM(s)
Vms = vapp.GetChildrenVms();
foreach (VM vm in Vms)
{
    Console.WriteLine();
    // Access vSphere information for VM
    ...
    // VM Info from vSphere
    VimObjectRefType vmRef = vm.GetVMVmRef();
    Console.WriteLine("VirtualMachine: " + vmRef.moRefField);

    // Datastore Info from vSphere for VM
    VimObjectRefType datastoreRef = vm.GetVMDatastoreVmRef();
    Console.WriteLine("Datastore: " + datastoreRef.moRefField);

    // Host info form vSphere for VM
    VimObjectRefType hostRef = vm.GetVMHostVmRef();
    Console.WriteLine("Host: " + hostRef.moRefField);
}
```

Restoring vApps

During the restore process, the backup software typically restores a virtual machine in vSphere using the virtual machine configuration and disk files. In situations where the vApp has been lost from the vCloud Director inventory, the backup software needs to first restore the virtual machine in vSphere, and then import the virtual machine into vCloud Director.

Although the vApp may contain multiple virtual machines in the view of vCloud Director, the virtual machines are known individually to vSphere. To complete the restore operation, the backup software needs to re-create the restored vApp so that all the member virtual machines are created as child virtual machines of the vApp.

To re-create the vApp using the vCloud SDK for .NET, the backup software must use two method calls: `ImportVmAsVapp` and `ImportVmIntoVapp`. Use the `ImportVmAsVapp` method to create a vApp from any one of the child virtual machines. Then call the `ImportVmIntoVapp` method once for each remaining child virtual machine. The following example shows how to use both methods to create a vApp using the vCloud SDK.

```
// Importing Virtual Machines into vApps
/// <summary>
/// Reference to hold the vCloud Client reference
/// </summary>
private static VcloudAdminExtension extension = null;

vcloudClient.login(user, password);
extension = vcloudClient.getVcloudAdminExtension();

// Get references for known VIM Servers
Dictionary<string, ReferenceType> vimServerRefsByName = extension.GetVMWimServerRefsByName();

// Select VIM Server Reference
VMWimServer vimServer = VMWimServer.GetVMWimServerByReference(vcloudClient,
vimServerRefsByName[vimServerName]);
...
// Import first VM from VIM server as vApp:
ImportVmIntoVAppParamsType importVmIntoVAppParamsType = new ImportVmIntoVAppParamsType();
importVmIntoVAppParamsType.vmMoRefField = moref; // vSphere ID from backup data.
importVmIntoVAppParamsType.vdcField = vdcRef; // vDC where the new vApp will be created.
Vapp vapp = vimServer.ImportVmAsVApp(importVmAsVAppParamsType); // Task is embedded in vapp.
...
foreach (VM vm in vms)
{
    // Import remaining VMs from VIM Server into existing vApp:
    ...
    importVmIntoVAppParamsType.vmMoRefField = moref; // vSphere ID from backup data.
    importVmIntoVAppParamsType.vAppField = vapp; // vApp to hold restored VMs.
    Task task = vimServer.ImportVmIntoVApp(importVmIntoVAppParamsType);
    ...
};
```

The following example shows the corresponding REST API calls used to rebuild a vApp in vCloud Director.

```
POST https://vCloud/api/admin/extension/vimServer/id/importVmAsVApp
POST https://vCloud/api/admin/extension/vimServer/id/importVmIntoExistingVApp
```

Conclusion

This chapter provided an overview of how to use the vCloud SDK for .NET to back up and restore vApps in vCloud Director. This information serves as a guide to using the vCloud SDK for writing backup and restore software. Other documentation is required to supplement aspects not described in this chapter.

The examples in this chapter are not intended to be complete. They are intended only to illustrate the method calls you would use during backup and restore operations with vCloud Director and vCenter Server. For more detail about the SDK methods and examples of their use, see the *vCloud SDK for .NET Developer's Guide*.

Virtual Disk Mount API

To perform file based restore, you can use the disk mount API (`vixMntapi`) for local and remote mounting of virtual disks. `VixMntapi` involves a separate library for programs to load.

Note As of VDDK 6.7.1, the `VixMntapi` library for Windows and Linux supports NBDSSL, HotAdd, and SAN transport. For earlier VDDK versions, and when used with earlier vSphere releases, the `vixMntapi` library for Linux supported only file and NBD transport.

This chapter includes the following topics:

- [The VixMntapi Library](#)
- [Programming with VixMntapi](#)
- [Sample VixMntapi Code](#)
- [Restrictions on Virtual Disk Mount](#)

The VixMntapi Library

The `VixMntapi` library supports guest operating systems on multiple platforms. On POSIX systems it requires FUSE mount, available on recent Linux systems, and freely available on the SourceForge Web site. Definitions are contained in the following header file, installed in the same directory as `vixDiskLib.h`:

```
#include "vixMntapi.h"
```

Types and Structures

This section summarizes the important types and structures.

Operating System Information

The `VixOsInfo` structure encapsulates the following information:

- Family of the guest operating system, `VixOsFamily`, one of the following:
 - Windows (NT-based)
 - Linux

- Netware
- Solaris
- FreeBSD
- OS/2
- Mac OS X (Darwin)
- Major version and minor version of the operating system
- Whether it is 64-bit or 32-bit
- Vendor and edition of the operating system
- Location where the operating system is installed

Disk Volume Information

The `VixVolumeInfo` structure encapsulates the following information:

- Type of the volume, `VixVolumeType`, one of the following:
 - Basic partition.
 - GPT – GUID Partition Table.
 - Dynamic volume, including Logical Disk Manager (LDM).
 - LVM – Logical Volume Manager disk storage. Not supported with Linux.
- Whether the guest volume is mounted on the proxy.
- Path to the volume mount point on the proxy, or NULL if the volume is not mounted.
- On Windows, `numGuestMountPoints` is the number of times a basic volume is mapped to a drive letter, or 0 if the volume is not mounted. IDE and boot disk come first. Unimplemented on Linux.
- Mount points for the volume in the guest.

Function Calls

To obtain these functions, load the `vixMntapi` library separately from the `vixDiskLib` library. On Windows, compile with the `vixMntapi.lib` library so your program can load the `vixMntapi.dll` runtime.

These calls can be used to mount and read Windows virtual disks on Windows hosts (with at least one NTFS volume) or Linux virtual disks on Linux hosts. Cross-mounting is restricted, though it is possible to mount a virtual disk with a mix of formats, if the mounted partition was formatted with Windows.

You should run only one `vixMntapi` program at a time on a virtual machine, to avoid conflict between registry hives. See [Multithreading Considerations](#) for advice on worker threads.

Available functions in the library are listed below. Under parameters, [in] indicates input, and [out] indicates output parameters. Functions that return `vixError` return `VIX_OK` on success, otherwise a VIX error code.

VixMntapi_Init()

Initializes the library. This is similar to `VixDiskLib_InitEx()` – see [Initialize Virtual Disk API](#). You should call `VixMntapi_Init()` only once per process.

```
VixError
VixMntapi_Init(uint32 majorVersion,
               uint32 minorVersion,
               VixDiskLibGenericLogFunc *log,
               VixDiskLibGenericLogFunc *warn,
               VixDiskLibGenericLogFunc *panic,
               const char *libDir,
               const char *configFile);
```

Parameters:

- `majorVersion` [in] VixMntapi major version number, currently must be 1 (one).
- `minorVersion` [in] VixMntapi minor version number, currently must be 0 (zero).
- `log` [in] Callback function to write log messages.
- `warn` [in] Callback function to write warning messages.
- `panic` [in] Callback function to report fatal errors.
- `libDir` [in] and `configFile` [in] as for `VixDiskLib_InitEx()`, allowing you to `tmpDirectory`.

VixMntapi_Exit()

Cleans up the VixMntapi library. You should call `VixMntapi_Exit()` only once per process

```
void VixMntapi_Exit();
```

VixMntapi_OpenDiskSet()

Opens the set of disks for mounting on a Windows virtual machine. All the disks for a dynamic volume or Logical Disk Manager (LDM) must be opened together.

```
VixError
VixMntapi_OpenDiskSet(VixDiskLibHandle diskHandles[],
                     int numberOfDisks,
                     uint32 openMode,
                     VixDiskSetHandle *diskSet);
```

The `VixDiskLibHandle` type, defined in `vixDiskLib.h`, is the same as for the `diskHandle` parameter in the `VixDiskLib_Open()` function, but here it is an array instead of a single value.

Parameters:

- `diskHandles` [in] Array of handles to open disks.
- `numberOfDisks` [in] Number of disk handles in the array.

- `openMode` [in] Must be 0 (zero).
- `diskSet` [out] Disk set handle to be filled in.

If you want to mount disks on a Windows system, first call `VixDiskLib_Open()` for every disk, then use the returned disk handle array to call `VixMntapi_OpenDiskSet()`, which returns a disk set handle.

If you want to mount disks on a Linux system, call the function `VixMntapi_OpenDisks()`, which opens and creates the disk set handle, all in one function.

VixMntapi_OpenDisks()

Opens disks for mounting on a Linux virtual machine, or disk sets on a Windows virtual machine. `VixMntapi` supports whatever file systems the proxy supports. On Linux, `VixMntapi` does not support Logical Volume Manager (LVM), although vendors can write their own scripts to support LVM disks.

```
VixError
VixMntapi_OpenDisks(VixDiskLibConnection connection,
                   const char *diskNames[],
                   size_t numberOfDisks,
                   uint32 openFlags,
                   VixDiskSetHandle *handle);
```

Parameters:

- `connection` [in] The `VixDiskLibConnection` to use for opening the disks. Calls `VixDiskLib_Open()` with the specified flags for each disk to open.
- `diskNames` [in] Array of disk names to open.
- `numberOfDisks` [in] Number of disk handles in the array. Must be 1 for Linux.
- `flags` [in] Flags to open the disk.
- `handle` [out] Disk set handle to be filled in.

VixMntapi_GetDiskSetInfo()

Retrieves information about the disk set.

```
VixError
VixMntapi_GetDiskSetInfo(VixDiskSetHandle handle,
                        VixDiskSetInfo **diskSetInfo);
```

Parameters:

- `handle` [in] Handle to an open disk set.
- `diskSetInfo` [out] Disk set information to be filled in.

VixMntapi_FreeDiskSetInfo()

Frees memory allocated by `VixMntapi_GetDiskSetInfo()`.

```
void VixMntapi_FreeDiskSetInfo(VixDiskSetInfo *diskSetInfo);
```

Parameter:

- `diskSetInfo` [in] OS info to be freed.

VixMntapi_CloseDiskSet()

Closes the disk set. Note, `vixDiskLib_Disconnect()` invalidates open file handles, so call this function first.

```
VixError  
VixMntapi_CloseDiskSet(VixDiskSetHandle diskSet);
```

Parameter:

- `diskSet` [in] Handle to an open disk set.

VixMntapi_GetVolumeHandles()

Retrieves handles to volumes in the disk set. The third parameter `VixVolumeHandle` can be a volume handle or an array of volume handles. If you pass an array this function returns the volume handle for the first volume only. If you pass a pointer (such as `VixVolumeHandle *volumeHandles`) it returns all the volume handles.

```
VixError  
VixMntapi_GetVolumeHandles(VixDiskSetHandle diskSet,  
                           int *numberOfVolumes,  
                           VixVolumeHandle **volumeHandles);
```

Parameters:

- `diskSet` [in] Handle to an open disk set.
- `numberOfVolumes` [out] Number of volume handles.
- `volumeHandles` [out] Volume handles to be filled in.

VixMntapi_FreeVolumeHandles()

Frees memory allocated by `VixMntapi_GetVolumeHandles()`.

```
void VixMntapi_FreeVolumeHandles(VixVolumeHandle *volumeHandles);
```

Parameter:

- `volumeHandles` [in] Volume handle to be freed.

VixMntapi_GetOsInfo()

Retrieves information about the default operating system in the disk set.

To get operating system information, `VixMntapi_GetOsInfo()` requires the system and boot volumes to be already mounted. It does not dismount the system volume at the end of this function. Your application should be prepared to handle the “volume already mounted” error gracefully.

This function is effective only when used with operating systems of the same type. For instance, a `VixMntapi` program running on Windows can provide information about the VMDK of a Windows virtual machine, but not about the VMDK of a Linux virtual machine.

```
VixError
VixMntapi_GetOsInfo(VixDiskSetHandle diskSet,
                   VixOsInfo **info);
```

Parameters:

- `diskSet` [in] Handle to an open disk set.
- `info` [out] OS information to be filled in.

VixMntapi_FreeOsInfo()

Frees memory allocated by `VixMntapi_GetOsInfo()`.

```
void VixMntapi_FreeOsInfo(VixOsInfo* info);
```

Parameter:

- `info` [in] OS info to be freed.

VixMntapi_MountVolume()

Mounts the volume. After mounting the volume, use `VixMntapi_GetVolumeInfo()` to obtain the path to the mounted volume. This mount call locks the source disks until you call `VixMntapi_DismountVolume()`. The `VixMntapi_MountVolume()` function cannot mount Linux swap or extended partitions.

```
VixError
VixMntapi_MountVolume(VixVolumeHandle volumeHandle,
                     Bool isReadOnly);
```

Parameters:

- `volumeHandle` [in] Handle to a volume.
- `isReadOnly` [in] Whether to mount the volume in read-only mode. Does not override `openMode`.

VixMntapi_DismountVolume()

Unmounts the volume.

```
VixError
VixMntapi_DismountVolume(VixVolumeHandle volumeHandle,
                          Bool force);
```

Parameters:

- `volumeHandle` [in] Handle to a volume.
- `force` [in] Force unmount even if files are open on the volume.

VixMntapi_GetVolumeInfo()

Retrieves information about a disk volume. Some information, such as the number of mount points, requires you to set the open read-only flag. Some information is available only if a volume was previously mounted by `VixMntapi_MountVolume()`. The Windows registry returns volume information only for mounted disks. On Windows the `VixMntapi_GetVolumeInfo()` call returns a symbolic link from the `VixVolumeInfo` structure in the form `\\.\vstor2-mntapi10-shared-<longhexnum>\`. You can transform this symbolic link into a target path by replacing `\\.` with `\Device` and deleting the final backslash, then map a drive letter with `DefineDosDevice(DDD_RAW_TARGET_PATH, ...)` and proceed as if you have a local drive. Alternatively on Windows, you can open a volume with `CreateFile()` and traverse the file system with `FindFirstFile()`.

```
VixError
VixMntapi_GetVolumeInfo(VixVolumeHandle volumeHandle,
                        VixVolumeInfo **info);
```

Parameters:

- `volumeHandle` [in] Handle to a volume.
- `info` [out] Volume information to be filled in.

VixMntapi_FreeVolumeInfo()

Frees memory allocated in `VixMntapi_GetVolumeInfo()`.

```
void VixMntapi_FreeVolumeInfo(VixVolumeInfo *info);
```

Parameter:

- `info` [in] Volume info to be freed.

Programming with VixMntapi

At the top of your program, include `vixMntapi.h` along with any other header files you need. Structures and type definitions are declared in the include file, so you do not need to create them or allocate memory for them.

Call `VixMntapi_Init()` to initialize the library in your application. This function takes major and minor version number to account for future extensions. You can provide your own logging, warning, or panic functions to substitute for the default VixMntapi handlers, and custom library and temporary directories.

Call `VixMntapi_OpenDiskSet()` to open a set of virtual disks for mounting. Pass a set of disk handles obtained from the `VixDiskLib_Open()` call. The `VixMntapi_OpenDiskSet()` function also expects number of disks to open, an optional open mode, and a parameter to pass back the resulting disk-set handle.

File System Support

Traditional Windows file systems (including FAT, FAT32, and NTFS) are supported. ReFS is supported but read-only for VixMntapi. Linux file systems (including ext2, ext3, ext4) are supported if the proxy machine supports them. VixMntapi depends on an operating system for file attributes such as compression, encryption, hidden files, ACL, and alternate streams. If a vixMntapi-linked application runs on a virtual machine that supports these attributes, vixMntapi can support them. Windows basic volumes and simple dynamic volumes are supported for writing, but spanned, striped (RAID-0), mirrored (RAID-1) and parity (RAID-5) volumes are supported read-only for VixMntapi.

You must open a disk set read/write to obtain the OS information for dynamic volume types including LDM and LVM. If you cannot open a base disk read/write, create a child disk in front, and open it read/write. In a multi-boot setup, only the first entry #0 is opened.

The order of mounting is important. For instance, mount top-level directories before subdirectories, and drives with dependencies after drives that they depend on. Mount points are not enumerated, nor are they restored. When you mount one volume, the other volumes are not implicitly mounted also.

Diagnostic Logging for VixMntapi

As of VDDK 6.7.1, logging is available to help diagnose behavior of the VixMntapi library. Currently this facility is available for Linux but not Windows.

The output file is named `vixMntapi.log` and appears in the same directory as other log files, as set by the `tmpDirectory` line in the VDDK configuration file passed as the seventh parameter to `VixDiskLib_InitEx`. Logging levels are the same as for `vixDiskLib.transport`:

- 0 = Panic (failure)
- 1 = Error
- 2 = Warning
- 3 = Audit

- 4 = Info
- 5 = Verbose
- 6 = Trivia

Read-Only Mount on Linux

As of VDDK 6.7.1, read-only mount is supported on Linux, as it was previously on Windows. This section describes a Linux solution for earlier VDDK releases. Now applications can mount the base disk of a snapshot with the read-only flag.

Here are possible use cases for read-only mounting of virtual disks:

- Avoid accidentally writing data to the disk, which is opened read/write mode.
- Retain current disk data after the VM is powered off.
- Use previous VM as a restore point by reverting to its original snapshot.

In VDDK 6.7.0 and before, Linux VixMntapi did not support read-only access. To mount a disk read-only, applications had to either mount the virtual disk of a powered off virtual machine, or mount the snapshot of a powered on virtual machine. The VixMntapi library can combine the two techniques to create read-only disk, as below.

To mount disks while saving a read-only copy:

- 1 Power off the VM if it is on.
- 2 Create a snapshot. Optionally revert to a previous snapshot if you want.
- 3 Connect to the VM for read/write access with `VixDiskLib_Connect` or `VixDiskLib_ConnectEx`.
- 4 Call `VixMntapi_OpenDisks` to open the current (not the snapshot) VM disk in read/write mode.
- 5 Mount volumes to access files. Write operations can be performed, but they write to the redo log of the current VM disk, not to the snapshot.
- 6 Close the disk and disconnect.
- 7 Revert to the snapshot created in step 2, to eliminate any write changes. Delete the snapshot.
- 8 Power on the VM if it was on before.

Sample VixMntapi Code

You call the VixMntapi functions after initializing VixDiskLib, connecting to a virtual machine, and opening a disk handle. The following example shows test code for Windows with the correct order of function calls.

```
MountTest() {
    vixError = VIX_ERR_CODE(VixDiskLib_Init() );
    vixError = VIX_ERR_CODE(VixMntapi_Init() );
    VixDiskLib_ConnectEx(&connectParams, TRUE, NULL, NULL, &connection));
    diskHandles = GetMyDiskHandles(diskPaths, connection, &connectParams, flags, &numberOfDisks);
    vixError = VIX_ERR_CODE(VixMntapi_OpenDiskSet(diskHandles, numberOfDisks, flags, &diskSet));
    GetOsInfo(diskSet);
}
```

```

vixError = VIX_ERR_CODE(VixMntapi_GetVolumeHandles(diskSet, &numberOfVolumes, &volumeHandles));
for(size_t i = 0; i < numberOfVolumes; i++) {
    VixVolumeHandle volumeHandle = volumeHandles[i];
    VixVolumeInfo *volumeInfo;
    vixError = VIX_ERR_CODE( VixMntapi_MountVolume(volumeHandle, TRUE) );
    vixError = VIX_ERR_CODE( VixMntapi_GetVolumeInfo(volumeHandle, &volumeInfo) );
    VixMntapi_FreeVolumeInfo(volumeInfo);
    VerifyMountedVolume();
    CleanupMountedVolume(volumeHandle, volumeInfo);
}
VixMntapi_FreeVolumeHandles(volumeHandles);
vixError = VIX_ERR_CODE( VixMntapi_CloseDiskSet(diskSet) );
FreeMyDiskHandles(diskHandles, numberOfDisks);
VixMntapi_Exit();
VixDiskLib_Exit();
}

```

Restrictions on Virtual Disk Mount

The following limitations apply when mounting virtual disks:

- You cannot mount virtual disks that are in use by a running or suspended virtual machine. You can mount virtual disks from any powered off virtual machine, or base disks when a virtual machine is running read-only off a snapshot.
- You can mount the last snapshot in a chain read/write, but you must mount previous snapshots read-only.
- If you specify a virtual disk with snapshots on a powered off virtual machine, VixMntapi locates and mounts the last snapshot in the disk chain. While a disk is mounted, do not revert to a previous snapshot using another VMware interface – this would make it impossible to unmount the partition.
- You cannot mount virtual disk if any of its .vmdk files are encrypted, compressed, or read-only. However you can change these attributes and then mount the virtual disk.
- With Windows, you must mount virtual disks on drive D: or greater, and choose a drive letter not in use.
- With Linux, kernel version 2.6 or higher is required to run the FUSE (file system in user space) module. You cannot mount Linux swap or extended partitions. Logical Volume Manager (LVM) is not supported.
- On Linux virtual machines before VDDK 5.5, you could not mount previous snapshots in the chain.
- You can mount Windows virtual disks on Windows hosts (with an NTFS volume) or Linux virtual disks on Linux hosts. Cross-mounting is restricted but may be allowed for cross-formatted file systems.
- The C: boot driver should be on scsi:0:0, and all disks should be opened in SCSI order (0:0, 0:1, 0:2, 1:0, 1:1, 1:2, etc.) before mounting any of them.

Errors Codes and Open Source

This chapter includes the following topics:

- [Recent Changes](#)
- [Finding Error Code Documentation](#)
- [Troubleshooting Dynamic Libraries](#)
- [Open Source Components](#)

Recent Changes

In vSphere 6.0, the VDDK libraries were changed to return `VIX_E_OUT_OF_MEMORY` when an ESXi host runs out of memory for network file copy (NFC). Previously, VDDK would hang during I/O operations.

Error 2 – `VIX_E_OUT_OF_MEMORY`

Memory allocation failed. Out of memory.

Finding Error Code Documentation

For a list of Virtual Disk API error codes, see the online reference guide *Introduction to the VixDiskLib API*:

- Windows – `C:\Program Files\VMware\VMware Virtual Disk Development Kit\doc\intro.html`
- Linux – `/usr/share/doc/vmware-vix-disklib/intro.html`

In a Web browser, click the Error Codes link in the upper left frame, and click any link in the lower left frame. The right-hand frame displays an alphabetized list of error codes, with explanations.

Association With VIX API Errors

The Virtual Disk API shares many errors with the VIX API, which explains the VIX prefix. The error codes for the VIX API are likely to be the same, or almost the same as, a comparable release of the VDDK.

For information about the VIX API, including its online reference guide to functions and error codes, see the developer support section of the VMware Web site:

<https://www.vmware.com/support/developer/vix-api/index.html>

Interpreting Errors Codes

A VIX error is a 64-bit value. A value of VIX_OK indicates success, but otherwise (if there is an error), several bit regions in the 64-bit value might be set. The least significant 16 bits are set to the error code described for VIX errors. More significant bit fields might be set to other values.

As for the VIX API, use the macro `VIX_ERROR_CODE(err)` to mask off bit fields not used by the VDDK.

Troubleshooting Dynamic Libraries

Problem

On Windows, the SSL library is placed in the same directory as other vixDiskLib dynamically loaded libraries. On Linux, functions that load the libraries `libssl.so.0.9.8` and `libcrypto.so.0.9.8` do the following:

- 1 Attempt to load them from the environment's `LD_LIBRARY_PATH` location.
- 2 Next, attempt to load them from the directory where `libvixDiskLib.so` is located.
- 3 Next, attempt to load them from the directory where the executable is located.
- 4 Failing that, exit with an error.

On install, VDDK creates the directory `/usr/lib/vmware-vix-disklib`, populated with 64-bit executables and libraries placed into subdirectories `bin64` and `lib64`. On determining the OS type, VDDK copies the vixDiskLib and vixMntapi libraries into `/usr/lib`. It does not copy `libssl.so.0.9.8` or `libcrypto.so.0.9.8` into `/usr/lib`.

On execution, the root user normally has no `LD_LIBRARY_PATH`, and `/usr/lib` is ahead of `/opt/vmware/lib` in the path. Running the `ldd` command can help diagnose where a program is getting `libvixDiskLib.so` and other libraries. The `/opt/vmware/lib` directory is neither created nor updated by the VDDK install script.

If you see the error “Failed to load library `libcrypto.so.0.9.8`” there are several solutions:

Solution

- Set or reset the `LD_LIBRARY_PATH` environment so it contains one of the directories above, `/lib64` and possibly `/bin64`, before it contains `/usr/lib`.
- Change the symbolic link in `/opt/vmware/lib` (or elsewhere) so it points to the directory above, `/lib64`.
- Copy the `libssl` and `libcrypto` libraries from `/usr/lib/vmware-vix-disklib/lib64` into `/usr/lib`.

Open Source Components

VDDK contains the following open source components, with license types indicated:

- Boost (BSD style license)
- Curl (MIT/X derivative license)
- Expat (BSD style license)
- FreeBSD (BSD license)
- ICU, International Components for Unicode (BSD style license)
- LibXML2 (MIT style license)
- OpenLDAP (OpenLDAP v 2.8 license)
- OpenSSL (OpenSSL license)
- Zlib (BSD license)

These open source components have the GNU library general public license:

- GetText (LGPL2.0)
- Glib (LGPL 2.0)
- LibFuse (LGPL2.0)
- Liblconv (LGPL2.0)